

# Planning and Constructing Rear-Ventilated Rainscreen Façades

## FVHF Guideline

Planning and Constructing  
Rear-Ventilated Rainscreen Façades

Last updated: 01/03/2018

## Foreword

The origins of rear-ventilated rainscreen façades can be found in historic shingle cladding. Due to the varying prevalence of raw materials in different parts of the country, the shingle was made from a range of materials; best known is wood shingle from southern Germany, sandstone from the Harz, and slate from the Rhineland. It would form the basis of today's technically advanced system with precisely matched components and various protective features.

The key characteristic of a rear-ventilated rainscreen façade is the separating air layer (rear ventilation space) between an insulated or uninsulated external wall and the cladding (weather protection). In addition to this construction advantage, the rear-ventilated rainscreen façade makes it possible to create architecturally sophisticated façades with a range of active and passive cladding elements.

The **FVHF guideline on planning and constructing rear-ventilated rainscreen façades** is a practical handbook for property developers, planners, and engineers.

It is an important source of information for the professional planning and construction of standard designs, but cannot cover all potential situations that may require more extensive or restrictive measures. Use of this guideline does not absolve anyone of responsibility for their actions.

### **Last technical update 03/2018**

All information and drawings provided represent the state of the art and the FVHF project group's experience based on it. FVHF e.V. will accept no liability for the information provided here. This also applies to misprints and later changes to technical information.

### **Credits**

Fachverband Baustoffe und Bauteile  
für vorgehängte hinterlüftete Fassaden e. V. (FVHF)  
Editing: Georg Stauber, FVHF project group

Association registered office:  
Kurfürstenstraße 129, D - 10785 Berlin, [www.fvhf.de](http://www.fvhf.de)  
Register of associations: Charlottenburg district court VR 20139 B  
Management: Ronald Winterfeld  
Chairperson of the Executive Board: Andreas Reinhardt

## Contents

1	General information .....	4
1.1	Validity .....	4
1.2	Terms .....	5
1.3	General planning information .....	6
1.3.1	Building documents .....	6
1.3.2	Technical approvals .....	6
1.3.3	Structural stability .....	7
1.3.4	Building engineering physics .....	8
1.3.5	Fire protection .....	9
1.3.6	Thermal protection .....	10
2	Planning and construction .....	10
2.1	Planning specifications .....	10
2.2	Content of building, specialist, and construction planning .....	11
2.3	Planning principles .....	11
2.4	Anchoring base .....	13
2.5	Anchoring, connecting, and fastening elements .....	15
2.5.1	Anchoring elements .....	15
2.5.2	Connecting elements .....	18
2.5.3	Fastening elements .....	18
2.6	Substructure .....	19
2.6.1	Timber substructure .....	19
2.6.2	Timber-metal substructure .....	20
2.6.3	Metal substructure .....	20
2.7	Thermal insulation .....	22
2.8	Rear ventilation .....	24
2.9	Cladding .....	25
3	Tolerances .....	27
3.1	General information .....	27
3.2	Shell tolerances/tolerances of preliminary works .....	27
3.3	Manufacturing tolerances in the system components .....	28
3.4	Production and installation tolerances .....	28
3.5	Recommendations for agreements of tolerances .....	28
3.6	Acceptance of completed work .....	29
4	Diagrammatic figures .....	29
5	References to standards (selection)/bibliography .....	41

## 1. General information

### 1.1 Validity

This guideline applies to the planning, dimensioning, design, and construction of vertical, inclined, and horizontal rear-ventilated rainscreen façades with claddings on metal and timber substructures.

It sets out principles and minimum requirements for permanent, structurally stable rear-ventilated exterior wall claddings.

In accordance with national trade regulations or manufacturer's specifications further standards and regulations apply to small-size-claddings (area  $\leq 0.4 \text{ m}^2$  and weight  $\leq 5 \text{ kg}$ ) and panel-size-claddings (width  $\leq 30 \text{ cm}$  and substructure support spacing  $\leq 80 \text{ cm}$ ) such as wall shingle, hand-crafted claddings etc.

Claddings on roof undersides are usually suspended, and reference in such cases should be made to the installation guidelines provided by the system manufacturer.

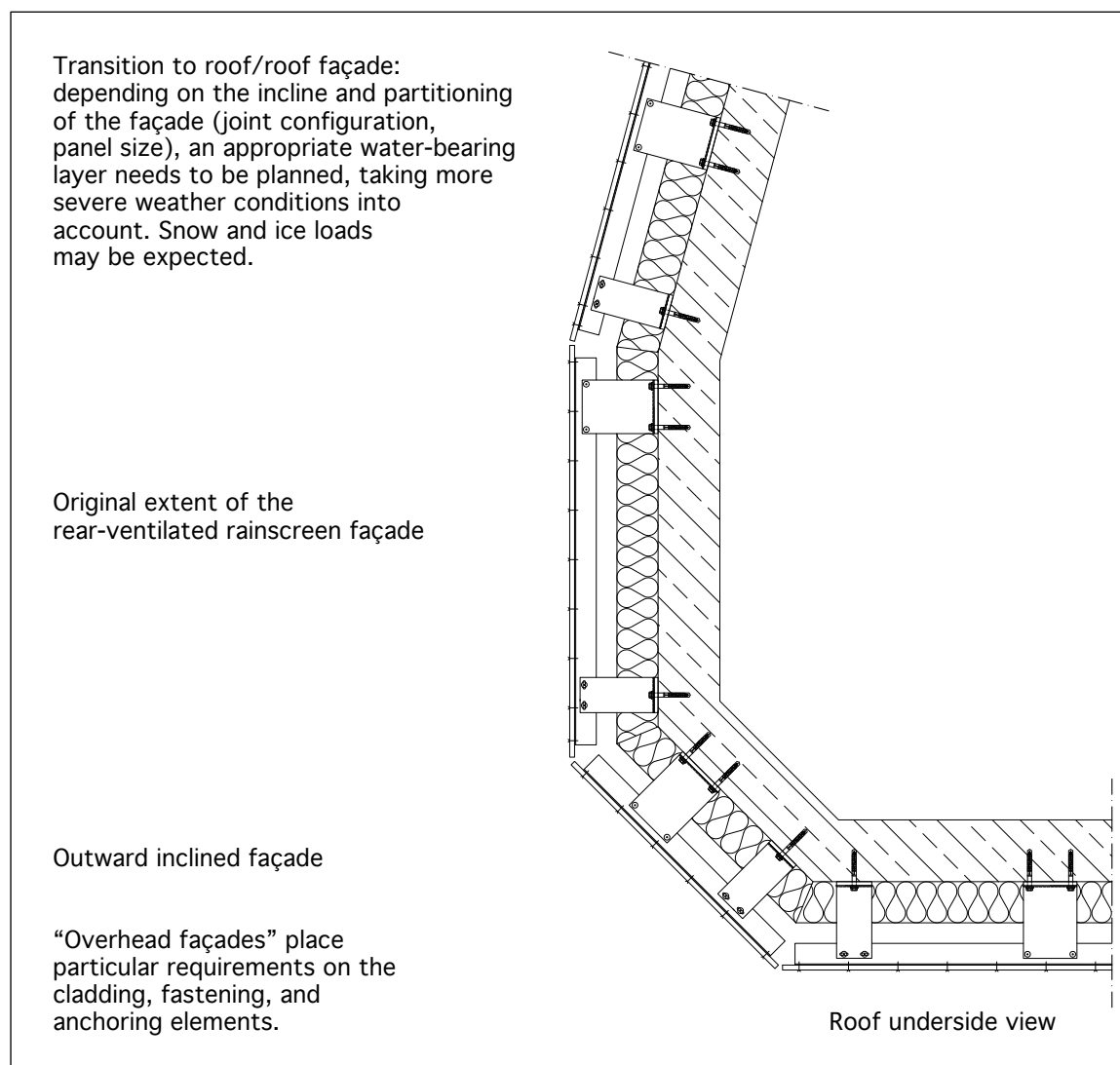

Figure 1: Areas of use

## 1.2 Terms

The rear-ventilated rainscreen façade consists of the following components

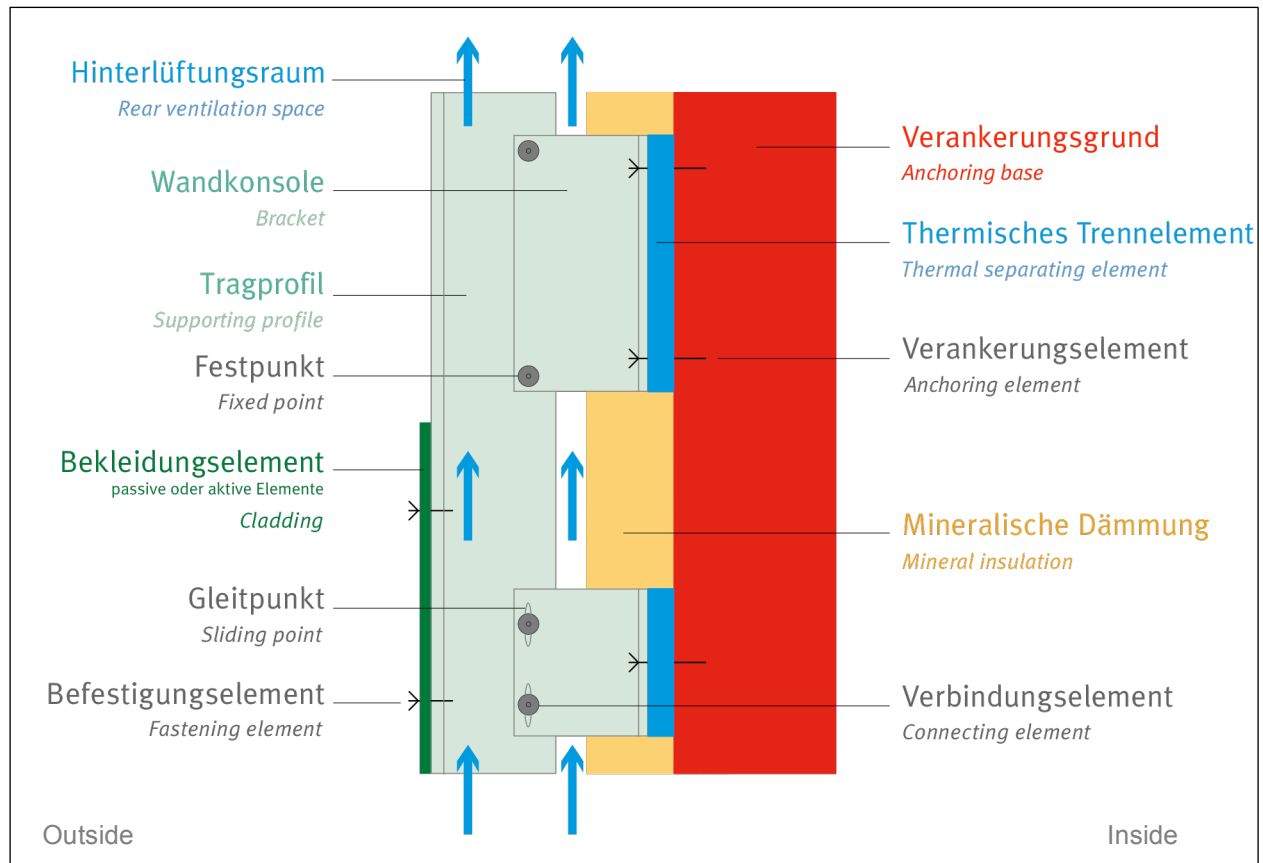

Figure 2: System components

### Anchoring base (external wall)

Space-enclosing layer of a building, usually a supporting wall.

### Anchoring element

Component that anchors the substructure in the anchoring base.

### Substructure

The substructure is the static link between the anchoring base and the cladding element. It consists of:

- thermal separating elements, as applicable
- wall brackets
- vertical and/or horizontal supporting profiles
- timbering, as applicable

### Connecting element

Component that interconnects the substructure elements (supporting profile, wall bracket).

### Thermal insulation

Optional insulating layer between anchoring base and rear ventilation space.

### Rear ventilation space

Space through which outside air flows between cladding element and thermal insulation/anchoring base.

### **Fastening element**

Component that fastens the cladding elements to the substructure.

### **Cladding element**

Outer layer of the rear-ventilated rainscreen façade used for weather protection and façade design.

### **Additional components, e.g.:**

- profiles for building corners, bases
- window sill, reveals, and lintels
- ventilation profile, wind barriers
- fire barriers
- parapet wall covers

## **1.3 General planning information**

### **1.3.1 Building documents**

The first step involves the property developer conducting a review of the need for planning permission to erect or modify a façade structure.

The construction of a rear-ventilated rainscreen façade may not be subject to approval, but this must never be assumed.

Even if construction work is not subject to approval, compliance with all other statutory requirements is required. Should the property developers not be an expert themselves, they must draw on the skills of professional planners and engineers to ensure proper planning and construction.

Key building documents include drawings, structural analyses as well as information on the design and the materials to be used. The documents must provide information on the substructure, the cladding, and the thermal insulation layer, including relevant properties and components.

Compliance with fire and thermal protection requirements (in accordance with DIN 4108 and the Energy Saving Ordinance (EnEV)) must be demonstrated.

### **1.3.2 Technical approvals**

Technical approvals must be obtained for a projected rear-ventilated rainscreen façade in accordance with local building regulations.

The type and scope of the technical approvals depend on the structure itself. They typically cover the following:

- fire behaviour
- sustainability, e.g. lifetime
- noise protection properties, if applicable
- mechanical properties, e.g. strength
- thermal protection properties
- information on maintenance and service

Proof of the applicability of the individual components (substructure; anchoring, connecting, and fastening elements; insulating materials and cladding elements) is to be provided in accordance

with standards (DIN / EN / ISO), a National Technical Test Certificate (abP), a National Technical Approval (abZ), a Construction Technique Permission or a respectively European Technical Approval (ETA), and a CE mark/declaration of performance. If this is not possible, a clearance on an individual basis (ZiE) is required.

If the abZ or the ETA for, for example, cladding materials includes information on the quality of the substructure and the fastening, anchoring, and connecting elements, then these aspects must be reflected in the final structure.

### 1.3.3 Structural stability

The proof of structural stability for the façade system, including all detailed records, must be provided in verifiable form by the specialist planner on the basis of applicable standards and guidelines.

This proof of structural stability must in particular include structural analyses of the substructure, the cladding elements and their attachment, and the anchoring and connecting elements. An allowance of at least 20 mm for the planned projection of the substructure (thermal insulation and rear ventilation space) must be applied for deviations in the space-enclosing wall. If larger flatness deviations are ascertained, they must be taken into account in the proof of structural stability.

The edge distances of the anchoring, connecting, and fastening elements must be adhered to.

The following actions must be considered:

- imposed loads in accordance with DIN EN 1991-1-1
- wind loads in accordance with DIN EN 1991-1-4
- snow and ice loads in particularly stressed sections
- restricted deformations/coercions
- special loads, e.g. attachments

In the case of a permeable external wall cladding, the dynamic pressure that arises in the rear ventilation space can be included in the wind load calculation, taking into account DIN 18516-1, section 5 in conjunction with DIN EN 1991-1-4 with the national annexe for Germany. Providing that the following points –

- depth of rear ventilation space < 100 mm
- joint covering  $\geq 0.75$  % (area of open joints/area of external wall cladding)
- wind barrier at the vertical building corners

– are adhered to, the wind load to be considered is reduced.

All components of the rear-ventilated rainscreen façade (in particular the cladding and substructure) typically require coercion-free installation and due consideration for length changes in specific materials caused by temperature and humidity. In the event of a restricted deformation in the external wall cladding and the substructure, the resulting stresses must be given due consideration in the proof of structural stability.

A mean installation temperature of +10°C and limit temperatures of -20°C to +80°C are to be taken into account for temperature-related shape and linear deformations. If components aligned in different directions are immovably interconnected, temperature differences of up to 35 K must be applied due to shading effects.

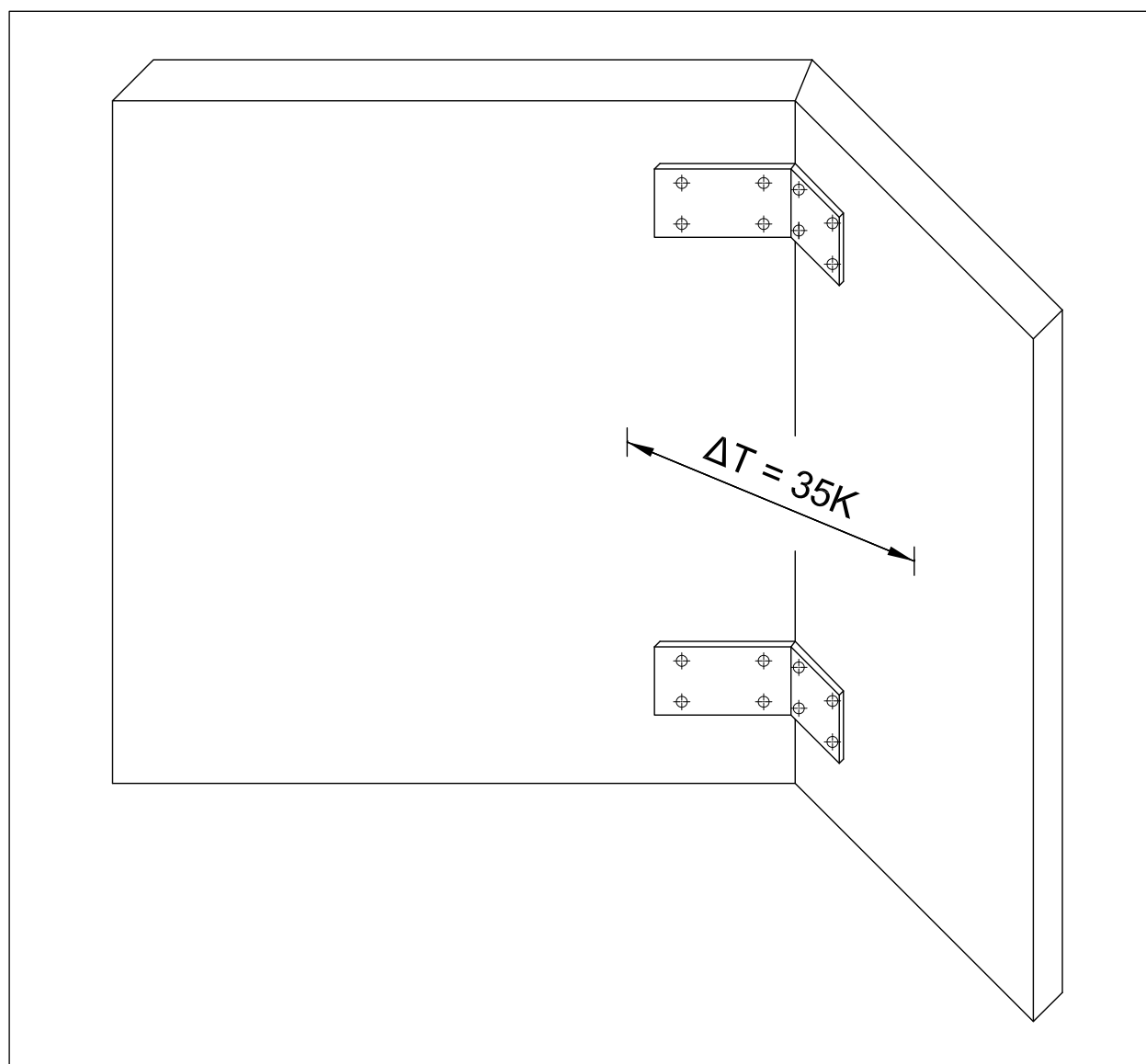

Figure 3: Temperature difference

### 1.3.4 Building engineering physics

Interaction between the external wall and the rear-ventilated rainscreen façade must be considered for thermal, moisture, noise, and fire protection.

The provisions set out in the following standards and regulations apply in particular:

- DIN 4108 – Thermal protection and energy economy in buildings
- DIN 4109 – Sound insulation in buildings
- EnEV (Energy Saving Ordinance)

Thermal bridges caused by the anchoring elements, substructure, joining plates, and any metal insulation holders etc. must be taken into account.

Design-related thermal bridges, e.g. from window joints or downpipes in the thermal insulation, must be assessed by the planner.



The rear-ventilated rainscreen façade does not have a space-enclosing function and does not contribute to a building's air tightness. Air tightness is ensured, for example, by the interior plastering and professionally installed door and window panels.

Requirements for the rear ventilation are specified in section 2.8.

### 1.3.5 Fire protection

With regard to fire protection requirements, DIN 18516-1 ("Cladding for external walls, ventilated at rear - Part 1: Requirements, principles of testing") refers to the most recent version of the Model List of Technical Building Rules issued by the Deutsches Institut für Bautechnik (DIBt) and annexe 2.6/11. These requirements have been adopted wholesale in the Model Administrative Provisions – Technical Building Rules (MVV TB, August 2017).

Special precautions to prevent fire spreading must be taken for rear-ventilated external wall claddings that feature cross-storey cavities or air gaps or cross over fire walls in accordance with Section 28(4) in conjunction with (5) and Section 30(7) of the Model Building Code (MBO1) These are specified as additional measures, e.g. in the form of horizontal and vertical fire barriers. Fire barriers prevent fire spreading in the rear ventilation space by cutting off or partially reducing the free cross-section.

By way of derogation from Section 28(3)(1) of MBO1, the thermal insulation must also be non-combustible.

Building material class requirements for rear-ventilated rainscreen façade components in accordance with the Model Building Code:



	height of construction*	substructure	insulation	cladding
	upt to 7 meter	combustible	combustible <sup>°</sup>	combustible
	7 – 22 meter	combustible**	non-combustible	heavily combustible**
	from 22 meter	non-combustible	non-combustible	non-combustible

Table 1: Building material requirements by building height

<sup>°</sup> The FVHF recommends non-combustible mineral insulating materials for all building classes of type WAB T3 WL(P).

\* Height as specified in the MBO is measured from the mean ground level to the floor level of the highest storey suitable for accommodation.

\*\* If the spread of fire is constrained for sufficiently long.

The FVHF guideline "Fire protection precautions for rear-ventilated rainscreen façades" interprets and further specifies these requirements. It is used to coordinate matters relating to a specific building with the relevant fire protection expert.

### 1.3.6 Thermal protection

Under the present Energy Saving Ordinance (EnEv), an energy performance certificate is required for all new builds and redevelopments. DIN 4108-2 specifies the minimum thermal insulation requirements for components.

One element of the energy performance certificate is a constructed assessment and balancing of thermal bridges in the building's outer shell. For external walls with rear-ventilated rainscreen façade, interaction between the anchoring base, substructure, and thermal insulation must be taken into account.

Selective or linear thermal bridges caused by a penetration of the thermal insulation layer required in the design are to be given due consideration when calculating the heat transfer coefficient.

The **FVHF guideline on determining the thermal influences of heat bridges with rear-ventilated rainscreen façades** must be observed when providing verification.

For external walls with rear-ventilated rainscreen façade, the thermal insulation layer and the presence of rear ventilation (external heat-transmission resistance) are taken into consideration for the layer structure in the component analysis ( $R_{Si} = R_{Se}$ ).

The free **FVHF efficiency tool** is recommended for preliminary dimensioning of the thermal insulation and substructure at an early stage of the planning process.

## 2. Planning and construction

### 2.1 Planning specifications

In order to coordinate the particular features of the different structural layers (e.g. supporting structure, intermediate structure, and outer shell), the building owner or the creator of the overall planning scheme and preliminary works planning must undertake to prepare a professional and proper execution plan.

The construction and installation planning does not substitute for a missing or incomplete execution plan. Planning responsibilities from the execution planning stage cannot be subsumed within the construction and installation planning.

It therefore follows that tolerances (specifically dimensional tolerances) in the preliminary works are to be coordinated and planned with respect to the tolerance compensation possibilities of the subsequent works.

The preliminary works (typically shell and window construction) must allow for these specified tolerances from the execution plan in their construction planning. One element of the execution planning involves planning all the components to avoid any collisions, e.g. anchor areas in reinforced concrete buildings, edge distances, etc.

## 2.2 Content of building, specialist, and construction planning

The core aspects of the execution planning (work phase 5) in accordance with Section 34 Annex 10 of HOAI 2013 include:

- development of an execution plan with all particulars required for execution (drawings and texts) on the basis of the design and approval planning up to the finished solution as the basis for further work phases
- execution, detail, and construction drawings by the type and size of the building and in the required scope and level of detail, in due consideration of all specialist requirements, e.g. for buildings on a scale of 1:50 to 1:1
- provision of work results as the basis for specialists involved in planning and the coordination and integration of their work
- updating of the planning schedule
- updating of the execution plan due to works-related adaptations during building construction
- review of required installation schedules for the building construction works planned by the building planner and of structural fittings for agreement with the execution plan

The execution planning must be sufficiently specific and detailed so that the construction and installation planning, as the precondition of installation, can follow seamlessly.

The basis of the construction and installation planning for a rear-ventilated rainscreen façade is a verifiable building structural analysis for the overall rear-ventilated rainscreen façade system (substructure, cladding, fastening, anchoring, and connecting elements), which must be prepared by the specialist planner on behalf of the property developer.

The specifications should set out creation of the building structural analysis and both the construction and installation planning for the rear-ventilated rainscreen façade as separate items.

## 2.3 Planning principles

A wide range of construction system is available to reflect the diversity of façade cladding types and their attachment, building structures on which rear-ventilated façades are mounted, and energy requirements for the overall façade system.

The architectural design and styling of rear-ventilated rainscreen façades and prevailing climatic and structural stresses determine the choice of materials, the design of the substructure, and the type of thermal insulation and attachment.

As required, necessary maintenance work and intervals for the façade must be given due consideration as early as the material selection stage.

### **Material combinations**

Electrically conductive connected components made of different metal materials may form a corrosion cell in the presence of an aerated electrolyte (e.g. atmospheric precipitation, condensate). This causes heavier corrosion on the less electrochemically noble material than when unpaired (bimetallic corrosion).

The intensity of corrosion depends on:

- the conductivity of the electrolyte
- the difference between the electrochemical potential in the two materials
- the surface area ratio between the electrically conductive connected metals (not in atmospheric conditions)

The risk of bimetallic corrosion increases with the potential difference of the metal combination. Even though the electrochemical series does supply certain practical information, the actual behaviour still cannot be fully specified. Reliable statements relating to bimetallic corrosion can only be made following practical testing.

All materials used must be matched appropriately; in particular, unfavourable interactions (e.g. bimetallic corrosion) must not occur.

A material's susceptibility to bimetallic corrosion in relation to its contact material can be calculated using the information in table 2, which also shows the compatibility of different metal materials in dry ambient conditions.

		material with small surface					
		aluminium	carbon steel casting	copper	stainless steel	galvanized steel	zinc
material with large surface	aluminium	+	0 / -	0 / -	+	0	0
	carbon steel casting	-	+*	+*	+*	-	-
	copper	-	-	+*	+*	-	-
	stainless steel	0 / -	-	+	+	-	-
	galvanized steel	+	+*	0	+	+	+
	zinc	+	+*	0	+	+	+

Table 2: Material combinations and surface area ratios

Legend: + = good, 0 = uncertain, - = poor

\* Combination only influences corrosion in each material insignificantly; not recommended due to heavy corrosion in the less noble material (source: Informationsstelle Edelstahl Rostfrei, leaflet 829)

In the event of ingress of moisture, bimetallic corrosion between different materials is possible in principle. Here, the principle holds that less noble metals “dissolve” on contact with more noble metals, i.e. they can corrode. The combination of small-size components made of noble metals (e.g. stainless steel screws) with large-size components made of less noble metals (e.g. galvanized steel) is accordingly less critical. Following DIN EN ISO 14713-1, the combination of stainless steel screws in other metal components is permissible without a separation layer.

In other cases, damaging effects caused by the combination of different metals and materials must be prevented by the placement of appropriate separation and intermediate layers.

If it is not possible to ensure that moisture cannot enter the space between components, aluminium components should be attached to a concrete base with a separation layer.

### Structural water runoff

Rainwater must be drained by means of structural measures. In the process, the minimum projections of window sill, cover plates, and roofs must be taken into account.

Window sill and, above all, roof projections make a substantial contribution to the visual appearance of a façade and are also an important part of the structural timber proofing in façades or substructures made of wood.

The outer window sill must enable controlled drainage of surface water. To aid this, a drip edge of  $\geq 30 - 50$  mm from the façade surface is recommended. The inclination of the window sill should not be less than  $5^\circ$  when installed. The window sill, with raised edges at their ends or with edging, require force-free installation in due consideration of the water runoff.

Parapet walls must drain with an incline of  $\geq 5^\circ$  relative to the flat roof. The clearance between the drip edge and the face of the component below it must be at least 20 mm. If using copper, the minimum projection is 50 mm. The front drip must cover the top edge of the façade and in particular the joint to be protected, depending on the building height:

- up to 8 m at least 50 mm
- 8 to 20 m at least 80 mm
- over 20 m at least 100 mm

Flush-mounted window sill or covers must be planned separately. Permanent scaffolding anchors in accordance with DIN 4426 must be located such that they are constantly accessible without the need to remove any cladding elements.

During planning and construction, applicable technical regulations, standards, and building regulation specifications must be observed. Deviations are permitted in isolated cases if the suitability of a selected design or technique has been sufficiently proven in both theory and practice. Written documentation and the approval of the property developer/building inspectorate are required.

## 2.4 Anchoring base

The type and quality of the anchoring base is a key criterion for the permissible load action caused by the selected cladding (material, size, and thickness), the configuration of the substructure, and the choice of correct anchoring elements.

The exact type and quality of the anchoring base must be determined and stated during the base analysis carried out by the building owner/planner. In this regard, the façade installation specialist must comply with inspection obligations in accordance with VOB/C.

Typical anchoring bases:

- concrete
- solid brick masonry (e.g. solid bricks, masonry bricks)
- perforated brick masonry (e.g. perforated or hollow bricks, honeycomb bricks)
- cellular concrete masonry
- wall plates (e.g. thin concrete plates, facing bricks)
- no-fines lightweight concrete
- curtain walls (e.g. double-leaf masonry)
- wooden load-bearing structure
- steel load-bearing structure

The characteristic loads of the anchoring elements in the various anchoring bases can be found in the respective technical approvals (ETA/abZ).

In the event of masonry with parameters that deviate from the ETA (e.g. apparent density, compressive strength, size) and thus have unknown load-bearing capacity, the actual load-bearing capacity must be calculated using pull-out tests on the anchoring base.

While doing so, the specifications in the ETA relating to “tests on the structure” and the declared information on the load-bearing capacity of the anchors in the respective usage categories (a, b, c, and d) of the anchoring base must be given consideration. The technical report “Execution and evaluation of job site tests” must be taken into account for injection anchor systems in masonry with ETA in accordance with ETAG 029 or EAS 330076-00-0604.

The characteristic loads specified in the ETA for the equivalent anchoring bases must not be exceeded. In individual cases, the number and position of test points must be agreed with the test engineer and the conditions for the relevant structure adjusted.

The following are some of the conditions that must be met for the calculation procedure for masonry and cellular concrete:

- If the straight joints in the wall are not to be filled with mortar, the rated value of the load-bearing capacity  $N_{Rd}$  is to be limited to 2.0 kN so as to preventively ensure that a brick cannot be pulled out of the wall. This restriction can be disregarded if using interlocked bricks in the wall or if the joints are due to be filled with mortar.
- If the masonry joints are not visible, the characteristic strength  $F_{Rk}$  is to be reduced by the factor  $\alpha_j = 0.5$ .
- The following must be taken into consideration if the masonry joints are visible (e.g. an unplastered wall):
  - The characteristic load-bearing capacity  $F_{Rk}$  may only be applied if the masonry is planned such that the joints will be filled with mortar.
  - If the masonry (walls) is designed such that the joints will not be filled with mortar, the characteristic load-bearing capacity  $F_{Rk}$  may only be used if the minimum edge distance  $c_{min}$  from the straight joints is adhered to. If this minimum edge distance  $c_{min}$  cannot be adhered to, the characteristic load-bearing capacity  $F_{Rk}$  is to be reduced by the factor  $\alpha_j = 0.5$ .

When creating the boreholes, the drilling method appropriate to the base and specified in the approval/assessment must be used. Examples:

- Hammer/percussion drilling with concrete and solid brick masonry
- Typically rotary drilling with perforated brick, cellular concrete, or no-fines concrete masonry

### **Double-leaf masonry/sandwich plate**

In the event of double-leaf masonry/sandwich plate, there is a responsibility to determine the leaf in which loads from the rear-ventilated rainscreen façade can be absorbed. This is particularly dependent on the type and load-bearing capacity of existing fastening elements in the outer leaf and requires a separate structural analysis.

If the curtain wall is not suitable for anchoring the rear-ventilated rainscreen façade, anchoring must be on the load-bearing leaf. A curtain wall with a non-load-bearing back anchor can be upgraded using double expansion wall repair anchors admitted for use by the building standards inspectorate.

### Wood particle boards/steel components

If the anchoring base is made of wood particle boards or industrial lightweight/steel skeleton steel components, anchoring elements approved for this purpose must be used. Any existing non-load-bearing layers (e.g. fire protection layer) must be taken into consideration in the structural analysis.

Any abZ/ETA cladding specifications regarding permissible deformations of the anchoring base must be observed in the planning and construction.

## 2.5 Anchoring, connecting, and fastening elements

The following metals may preferably be used without separate proof of corrosion protection:

- stainless steel in corrosion resistance class III/average<sup>2</sup> or above
  - e.g. material numbers 1.4-4-01, 1.4-4-04-, 1.4362, 1.4571, 1.4578
- aluminium alloys in accordance with DIN EN 1999-1-1
  - e.g. material numbers EN AW 6066, 6063, 6060,5754;
- hot-dip galvanised connecting elements in accordance with DIN EN ISO 10684 in strength class  $\geq 8.8$  with corrosion protection in accordance with DIN EN ISO 1461 in conjunction with DAST Guideline 022 and DIN EN 10025 with corrosion protection in accordance with DIN EN ISO 12944-5.

Reference is made to the “Material combinations” section (2.3) with regard to possible material combinations.

### 2.5.1 Anchoring elements

The substructure anchoring elements are selected on the basis of the anchoring base and the loads that occur.

The installation instructions and characteristic values set out in the applicable European Technical Approval (ETA) and the National Technical Approval (abZ) must be taken into account.

Drilling dust must usually be removed from the boreholes prior to fitting the anchoring elements.

Typical anchoring elements:

- Frame/long-shaft anchors (plastic anchor and associated special screw):  
The bulk of rear-ventilated rainscreen façades is anchored using frame/long-shaft anchors and a push-through technique. In accordance with the ETA/abZ, the polyamide anchor sleeves and the special screw must be supplied and installed as a matching unit. In accordance with the approval/assessment, zinc-plated steel anchor screws may also be used if the fastening unit is protected against ingress of moisture into the anchor shaft. The screw head itself and in particular the area where it meets the plastic sleeve must be coated with a soft-plastic permanently elastic bitumen oil combination coating (e.g. car underbody/cavity protection). The spray application of the coating has proven to be a suitable method here.

<sup>2</sup> In accordance with abZ Z-30.3-6 Annexe 1, in conjunction with DIN EN 1993-1-4 Annexe A

- Stainless steel expansion anchors:  
Another method of anchoring façade structures in concrete, e.g. for heavy façades and/or with large substructure spans, involves crack-compliant heavy-duty anchors made of metal.
- Injection anchors:  
Suitable for individual fastening and anchoring in bases with a low load-bearing capacity.

### **Non-load-bearing system with multiple fastenings**

Rear-ventilated rainscreen façades are non-load-bearing systems. This includes components that, aside from their own weight, only need to transfer wind loads to the anchoring base. As a rule, the anchoring can involve multiple fastenings. Long-shaft anchors with an approval (ETA) may only be used for multiple fastening of non-load-bearing systems. Multiple fastening can be specified by the number  $n$  of fastening points for the component and the number  $n_2$  of anchors per fastening point. In addition, the definition of the rated value of actions  $N_{sd}$  on a fastening point as the value  $\leq n_3$  (kN) ensures that the strength and stiffness requirements for the component being fastened are adhered to and that load displacement in the event of excessive slip or failure of an anchor does not need to be accounted for in the assessment of the component to be fastened.

The following limit values may be used for  $n_1$ ,  $n_2$ , and  $n_3$ :

$$n_1 \geq 4; n_2 > 1 \text{ and } n_3 > 4.5 \text{ kN}$$

or

$$n_1 \geq 3; n_2 > 1 \text{ and } n_3 > 3.0 \text{ kN}$$

A rear-ventilated rainscreen façade can typically be anchored with multiple fastenings in common bases using approved frame anchors with ETA in accordance with ETAG 020. The requirement here is a sufficiently stiff substructure to ensure this load displacement without individual components failing or becoming significantly deformed.

In order to secure the multiple fastenings in parapet areas, the base profile requires at least three fastening points or a load displacement function over the external supporting profiles.



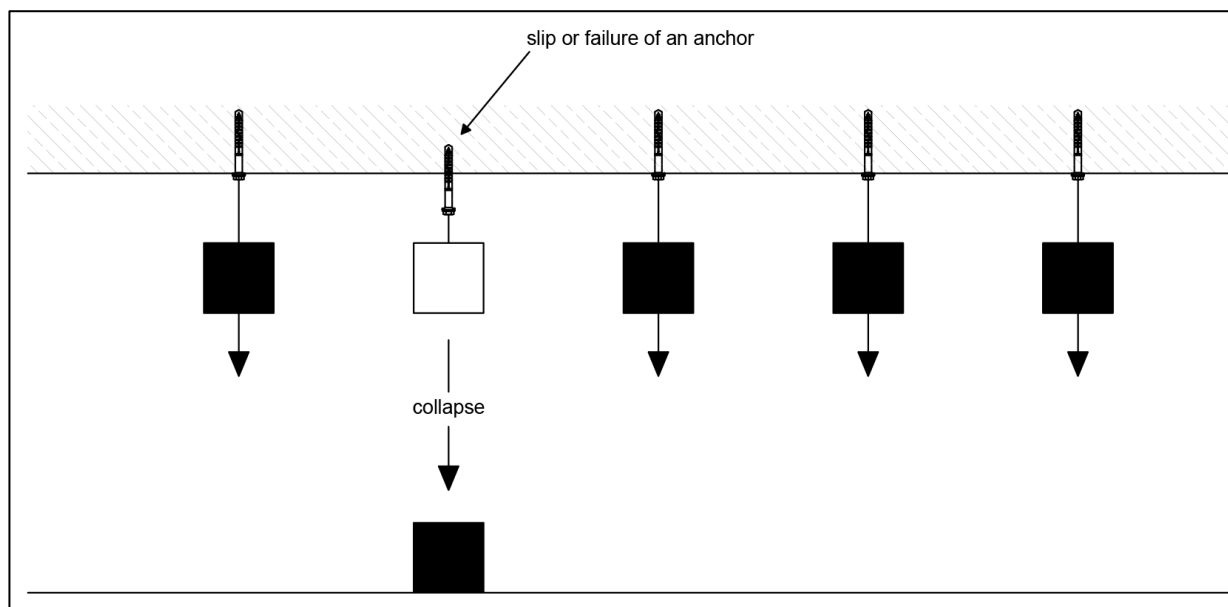

Figure 4: Individual fastening

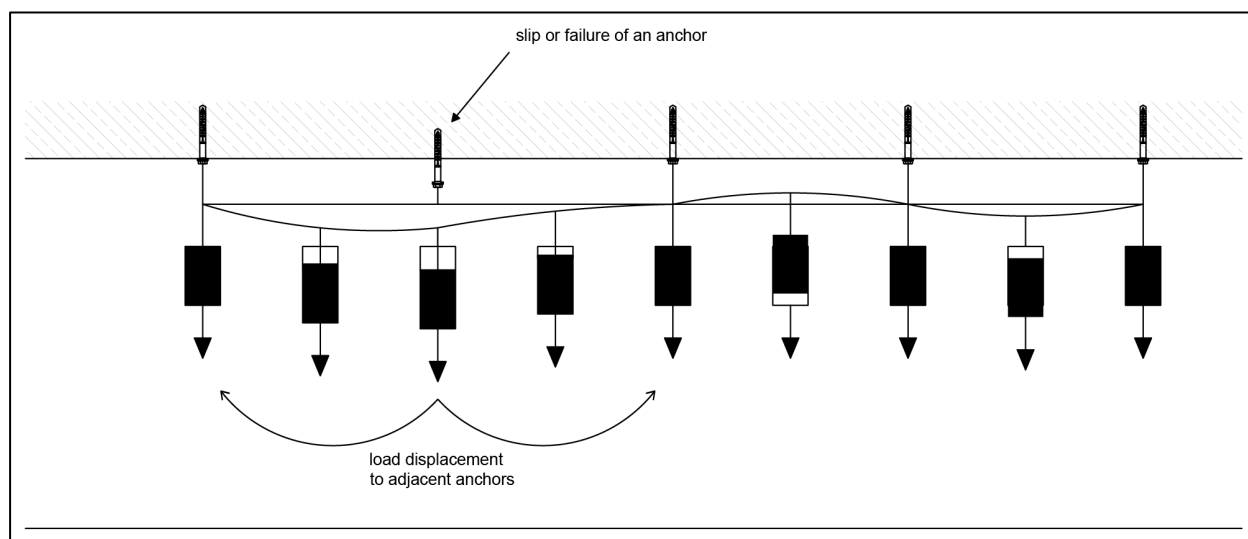

Figure 5: Multiple fastening

In the area of roof undersides, plastic anchors in accordance with ETAG 020 may only be used if no fire protection requirements are placed on the anchor.

If an individual fastening is present in masonry as a result of the design, injection technology in accordance with ETAG 029 must be used. This anchoring method is characterized by high load ratings, even in perforated bricks with comparatively low apparent density and compressive strength.

If an individual fastening is present in concrete as a result of the design, either metal anchors in accordance with ETAG 001, injection technology in accordance with 029, or nationally approved plastic frame anchors with approval for individual fastening in accordance with ETAG 001 must be used.

## 2.5.2 Connecting elements

In the event of timber substructures, the supporting battens are to be fastened to the main battens using screws, nails, or clamps.

Rivets or screws are to be used in accordance with manufacturer information or a structural analysis to connect the separate elements of the substructure made of metal. In the event of rivet joints, sliding points require force-free installation using rivet gauges; with screw connections, they require screws appropriate to the application.

The functional principle of special fixed and sliding point screws is essentially based on a thread adapted to the thickness of the profile and wall brackets in the area of the screw head.

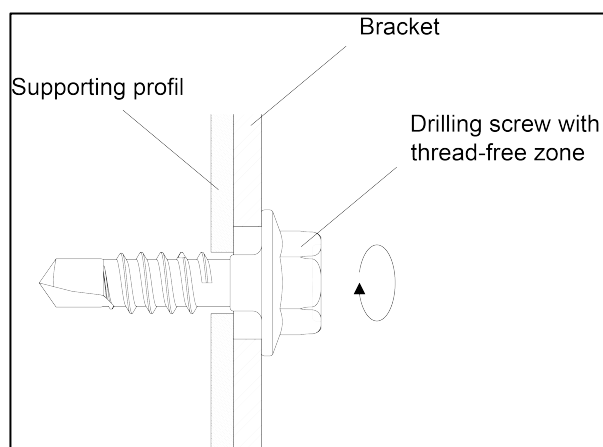

Figure 6: Sliding point screw

Connecting elements made of stainless steel must be A4 in accordance with DIN EN ISO 3506-1. Provided the application is set out in a National Technical Test Certificate (abP), the National Technical Approval (abZ), a Construction Technique Permission or the European Technical Approval (ETA), A2 stainless steels (in corrosion protection class II/moderate<sup>3</sup>) can also be used.

## 2.5.3 Fastening elements

The façade cladding can be fastened in a variety of ways – visibly or concealed.

Visible fastening involves the use of stainless steel screws (min. A2 stainless steel), aluminium or stainless steel blind rivets (with stainless steel mandrel), or clamp systems.

Concealed fastening uses undercut anchors, thread-forming or self-drilling screws, rivets, clamps, adhesive systems, hook-in systems (e.g. screws, hook connectors), ceramic composite components, or similar.

All fastening elements must be set out in the standards or the building inspectorate approvals/test certificates/assessments for the respective application. In the approvals/assessments, this is generally the case for claddings/overall systems, while the fastening elements are governed by their individual type approvals.

<sup>3</sup> In accordance with abZ Z-30.3-6 Annexe 1, in conjunction with DIN EN 1993-1-4 Annexe A

Non-regulated fastening elements may only be used if their suitability has been proven and, as applicable, approved by the building inspectorate.

## 2.6 Substructure

The substructure is the static link between the façade cladding and the building's external wall.

Due to the diversity of rear-ventilated rainscreen façade systems available on the market, there are a wide range of substructure systems that can be used. Today, the use of rear-ventilated cladding systems is not restricted to façades but has also been extended to cover roof undersides.

### 2.6.1 Timber substructure

Timber substructures have been used since the beginnings of rear-ventilated rainscreen façades.

The main components of a timber substructure:

- main battens
- counter battens, as applicable
- supporting battens/formwork

A range of configurations and designs for the substructure timber are possible depending on the thickness of the thermal insulation and the type of cladding.

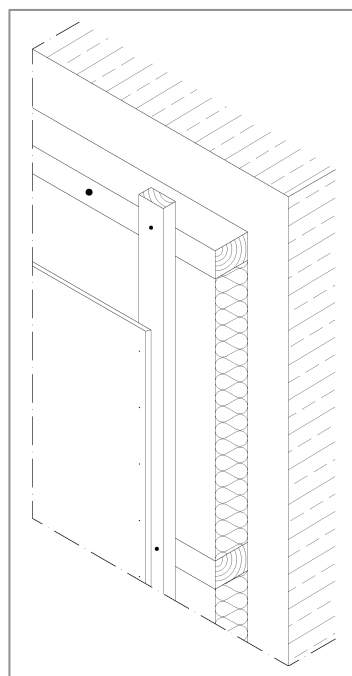

Figure 7: Two-layer substructure

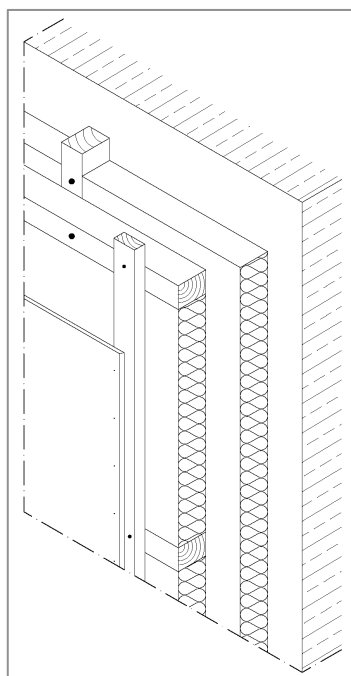

Figure 8: Three-layer substructure

Larger thermal insulation layer thicknesses require several layers of square timber to achieve the required clearance between the façade cladding and the base or the thermal insulation layer (stacked design): horizontal main battens with mounted vertical supporting battens, the cladding attached on top and the thermal insulating material as infilling between the main battens.

The supporting battens should preferably be installed vertically to ensure rear ventilation between the insulation layer and the cladding. Sufficient rear ventilation is to be ensured through the thickness of the supporting battens.

Full-area timber formwork or trapezoidal sheet steel is required as the fastening substrate for non-self-supporting façade cladding.

The design of the timber substructure and its connecting elements must comply with the specifications in DIN EN 1995-1-1 (Eurocode 5) or the relevant approvals/assessments.

Timber battens of grading class S10 in accordance with DIN 4074-1 or minimum strength class C24 in accordance with DIN EN 338 are used as the substructure for fastening the panels.

Particular attention must be paid to the structural timber protection in the execution planning (see DIN 68800-1 to DIN 68800-3 and DIN 68800-5).

EPDM joint tape has proven effective for supporting batten moisture protection when used as underlayment in the area of open vertical cladding joints. Open horizontal cladding joints must be structurally executed to match the cladding such that no water runoff is possible behind the system.

## 2.6.2 Timber-metal substructure

Hybrid designs are used for better adjustment of the structure, to compensate for flatness imperfections in the anchoring base, and to achieve greater insulating material thicknesses. When using these systems, the timber support structures are elevated on metal brackets.

The main elements of a timber-metal substructure:

- wall brackets
- metal main profiles or timber counter buttons, as applicable
- supporting battens/formwork

## 2.6.3 Metal substructure

The majority of substructures today are made of metal.

The main components of a metal substructure:

- wall brackets
- thermal separating element, as applicable
- vertical and/or horizontal supporting profiles

### 2.6.3.1 Wall brackets

These brackets are frequently made of aluminium (preferred material EN AW 6060 T 66) or stainless steel with corrosion resistance class III/moderate<sup>4</sup>.

Due to constantly increasing energy-related requirements, thermal separations are generally recommended between the anchoring base and the brackets.

### 2.6.3.2 Low thermal bridge wall brackets

Considering the need for energy-optimised cladding systems, the importance of substructure systems certified as featuring low thermal bridges or suitability for passive houses is increasing.

Current developments in the field integrate thermal separating elements in the bracket or are made in part or in whole of glass-fibre reinforced plastic.

These brackets are non-regulated construction products that require separate building inspectorate approval. In addition to structural stability, this approval also covers the components' fire protection classification. This (still) in part restricts their field of application.

There are now also systems with specially designed brackets made of stainless steel, in which heat transfer is reduced by the far lower thermal conductivity of the steel material and the specific reduction in the brackets' cross-sections.

Rod systems that replace or complement brackets and locally reduce the effect of thermal bridges due to the smaller cross-sections are also available on the market.

The majority of these systems have been optimised such that they are certified by the Passive House Institute.

### 2.6.3.3 Thermal separating

Local thermal bridges caused by substructure components are to be reduced in line with energy requirements by the placement of thermal separating elements.

### 2.6.3.4 Supporting profiles

The wall brackets are most commonly connected to profiles made of extruded aluminium (EN AW 6063 T 66 / EN AW 6060 T66). In isolated cases, however, stainless steel or steel profiles with appropriate corrosion protection are also used.

To achieve force-free absorption of the thermal length changes in the supporting profiles, fixed and sliding points are frequently formed in the connection between the profiles and the brackets.

A common method of forming fixed points is a connection using punched round holes in the bracket. For sliding points, the connection between the bracket/ supporting profile is effected with the aid of punched slotted holes in the bracket.

---

<sup>4</sup> In accordance with abZ Z-30.3-6 Annexe 1, in conjunction with DIN EN 1993-1-4 Annexe A

It is important that at sliding points the connecting elements are fitted centrally in the slotted holes to enable force-free absorption in both directions of thermal length changes in the supporting profiles.

In specific application cases, an individual analysis conducted by a specialist engineer as part of the structural analysis is required.

Depending on the cladding fastening method, they are installed directly on the base structure or on superstructures placed additionally on the base structure. One common method is to hook the cladding elements into matching horizontal supporting profiles by means of an agraffe system.

It should be noted that, even if the horizontal and vertical supporting profiles are connected, force-free absorption of thermal length changes must generally be assured by the formation of fixed and sliding point connections and the use of suitable connecting elements.

Depending on the type of cladding, direct installation on the base structure using rivets or screws is also possible for roof undersides. As with façades, panels may also be hanged in, for example using agraffes, depending on the system. Care must, however, be taken to ensure that the on-site cladding is secured in a force-free manner and that the agraffes are reliably prevented from disengaging.

The following metals may be used without separate proof of corrosion protection.

- stainless steels in corrosion resistance class III/moderate or above in accordance with a National Technical Approval Z-30.3-6
  - material numbers 1.4401, 1.4404, 1.4571, 1.4578, 1.4362, 1.4578
- Aluminium alloys in accordance with DIN EN 1999-1-1 and DIN 4113-1
  - e.g. material numbers EN AW 6060 T66, EN AW 6063 T66
- hot-dip galvanised connecting elements in accordance with DIN EN ISO 10684 in strength class  $\geq 8.8$  with corrosion protection in accordance with DIN EN ISO 1461 in conjunction with DAST Guideline 022
- steel grades in accordance with DIN EN 10025, with corrosion protection in accordance with DIN EN ISO 12944-5.

## 2.7 Thermal insulation

According to energy requirements in the valid EnEV or other structurally-related requirements, thermal insulation is generally required between the anchoring base and the rear ventilation space. Its thickness and thermal conductivity is stated on the thermal insulation certificate, in due consideration of thermal bridge effects in the respective substructure.

Based on DIN 18516-1, Section 28 of the MBO in conjunction with Annexe 2.6/4 of the MLTB, only non-combustible thermal insulating materials may be used from building class 4. In addition to thermal protection, the use of mineral wool insulating materials also has a positive effect on the façade's fire and noise protection. Due to their construction advantages, the FVHF therefore recommends mineral wool insulating materials of type WAB T3 WL(P) in accordance with DIN EN 13162.

When selecting an insulating material, the specifications set out in the approvals/assessments for the cladding elements and substructures must be observed.

The thermal insulation may optionally be lined with fleece. With open cladding joints, dark fleece linings create a shadow gap or hide the thermal insulation layer from view. The faces and joints need not be lined with fleece. This requires the use of water-repellent thermal insulation

boards over the entire cross-sectional area.

External wall constructions with open joints and thermal insulation with mineral fibres in accordance with DIN EN 13162 must have a flow resistance of at least  $AF_r > 5 \text{ kPa}\cdot\text{s}/\text{m}^2$ . Mineral fibres that meet this requirement do not need any further wind protection against cooling.

### **Attachment**

Insulating materials for rear-ventilated rainscreen façades must be permanently attached without any gaps. The insulating boards must be tightly bonded so that no straight-through cavities can arise between the base and insulating layer.

The insulating boards are installed on the supporting wall in accordance with DIN 18516-1, on average with five insulating material holders per  $\text{m}^2$ . The insulating material holders must comply with the building material class “normal flammable” – there are no other building inspectorate requirements.

If it is not possible or desirable to use insulating material holders, the boards can be attached using an adhesive approved for the application. Glued boards must be attached fully or using the spot-bead method to prevent back flow. The tensile strength perpendicular to the board orientation of the insulating material should be at least 1 kPa to absorb fixed and wind loads.

A number of insulating material suppliers offer the option to fasten the insulating boards using just one or two insulating material holders for each board. This practice represents a deviation from standard DIN 18516-1 and must be agreed for the specific building with the insulating material manufacturer and the building owner in advance.

Simple clamping of the boards between vertical or horizontal structural sections is normally not admissible.

### **Additional measures for large thermal insulating material thicknesses**

Due to increased requirements for the thermally insulating function of the external wall, insulating material thicknesses that in a single layer may be difficult to handle on the construction site are sometimes required. In such cases, the insulating boards are installed in two layers in an offset pattern.

### **Insulating material protection**

The thermal insulation must not be permanently directly exposed to the weather. In general, a cover on the top of the insulation is recommended, even during construction, to ensure that water cannot access the space behind the insulation.

The rear-ventilated rainscreen façade is considered resistant to heavy rain (stress group III, annual precipitation  $> 800 \text{ mm}$ ) as specified in DIN 4108-3. Open joints between the cladding panels do not negatively impact on rain protection (in accordance with table 5 of DIN 4108-3).

If the façade cladding has openings equivalent to at least five percent or a joint width  $> 15 \text{ mm}$ , additional structural measures for weather protection are recommended (e.g. joint backing or installation of an appropriate façade membrane).

## 2.8 Rear ventilation

In combination with sufficient air inlets and outlets, the rear ventilation space between the rear of the cladding and the thermal insulation layer or the external wall creates a practically permanent flow of air behind the cladding. Rear ventilation helps to drain moisture from the façade and external wall structures.

The following causes for the ingress or accumulation of moisture in the structure must be taken into account:

- Building moisture due to the relatively high water content of newly installed building materials (in particular wood, mortar, concrete)
- Driving rain, precipitation water, drifting snow, etc. penetrating the cladding joints/openings
- Condensate occurring on the inside of the cladding, e.g. with high outside air humidity and night-time cooling

In the summer, most of the heat is carried off by the rear ventilation space, which in the winter acts as a temperature buffer. This has a positive effect on the building's indoor climate.

The requirement for sufficient rear ventilation is fulfilled if the cladding is located at a distance of at least 20 mm from the external wall or thermal insulation. In due consideration of permissible material and structural tolerances, a rear ventilation cross-section of 30 to 50 mm must be planned. Specifications from approvals, standards, and building regulations must be observed when dimensioning the rear ventilation space.

Clearance may, for example, be locally reduced to up to 5 mm on the basis of the substructure, fire barriers, or wall unevenness.

Claddings comprises of vertical trapezoidal or corrugated boards may be placed on the thermal insulation in strips provided the minimum required rear ventilation cross section of 200 cm<sup>2</sup>/m is maintained.

With rear-ventilated rainscreen façade, vents must at minimum be provided at the base of the building and on the roof edge with cross-section of at least 50 cm<sup>2</sup>/m wall length. If the rear ventilation space is interrupted, e.g. by windows in the lintel area and below the window sill, the use of air inlets and outlets is recommended.

In the base area, openings for rear ventilation of the external wall cladding with a width of over 20 mm must be fitted with gratings; the free minimum cross-section of 50 cm<sup>2</sup>/m must be adhered to. This recommendation applies analogously to other openings.

The bottom end of the rear-ventilated rainscreen façade should typically be located at least 30 cm above the natural ground/surface covering. Its design must follow FLL recommendations for planning, building, and maintaining transition areas between open spaces and buildings. Smaller clearances must be agreed by the building owner and the manufacturers of the cladding and thermal insulation during the planning phase for the specific building.

In the perimeter area, appropriate thermal insulation must be used for the base area.



## 2.9 Cladding

The cladding forms the outer layer of the rear-ventilated rainscreen façade. It provides weather protection and a means of façade design. The following materials have proven effective as cladding:

### Large-size:

- concrete stone
- fibre-reinforced concrete
- fibrecement
- glass
- wooden composite boards
- ceramics
- laminates
- metal
- natural stone
- photovoltaics/solar-thermal energy
- plaster baseboard
- mineral wool boards
- textiles
- composite materials

### Small-size and panel-size:

- fibre-reinforced concrete
- fibrecement
- wood shingle, wooden boards
- ceramics
- laminates
- metal
- natural stone
- bricks

When planning the cladding, the following points need to be considered in addition to weather protection, building engineering physics, and structural stability requirements:

- type of fastening (visible or concealed)
- joint distribution (element size, joint layout, expansion joints, etc.)
- installation direction
- colour differences when changing material batches
- material reflections
- suitability (outdoor use, compatibility with materials) must be ensured when using elastic sealants (e.g. silicone) to prevent contamination on the façade surfaces and diffusion into the boards.

The cladding of a rear-ventilated rainscreen façade can generally be executed with open and closed joints or, for specific systems, without joints.

When using board materials, joints should generally have a width of 8 to 12 mm. Here, the joint width is influenced by the façade cladding, tolerances, installation temperature, and the thermal and hygric expansion of the material.

Special measures in consideration of any deformation that may occur must be taken in order to limit continuous cladding breakage in the event of local failure. The external wall cladding, for example, is to be divided up into areas of 50 m<sup>2</sup>. These measures are not required for cladding elements subject to brittle bending failure. Deviations may be specified in the approval.

In the event of a restricted deformation in the external wall cladding and the substructure, the resulting stresses (restraint stresses) must be given due consideration in the proof of structural stability.

Thermally induced length changes (in millimetres) of typical cladding materials are shown below for each metre of length, assuming an installation temperature of +10°C:

material	length changes (in millimetres, for each metre) assuming an installation temperature of +10°C	
	at -20 °C	at +80 °C
aluminium	-0,7	+1,6
stainless steel	-0,5	+1,1
fibrecement	-0,3	+0,7
glas	-0,3	+0,6
wood	-0,2	+0,4
ceramic	-0,1	+0,2
copper	-0,5	+1,2
zinc	-0,7	+1,5

Table 3: Temperature-dependent length change

The cladding may be visibly or concealed fastened. It is to be fastened in accordance with static requirements and abZ/ETA or manufacturer guidelines.

Force-free installation must be ensured when fastening the cladding, e.g. using sliding or fixed points.

With visible fastenings (screws, rivets), sliding points specific to the system are created using slotted holes or a sufficiently large hole diameter in the cladding elements.

Rivet fastenings has to be produced in a force-free manner using drill or rivet setting tool; screw fastenings, for example, by means of the non-threaded area behind the screw head or a depth-control stop.

If using clamps, clips, agraffes, or rails, force-free installation involves the movement joint between the cladding element and the fastening element or within the structure.

Positional stability of the cladding elements must be ensured by means of appropriate design measures.

For cladding elements, the edge distances of the fastening elements must be adhered to in accordance with the approval/assessment, manufacturer information, and the structural analysis.

Adhesive systems may only be used by trained and certified façade contractors. In this context, the specific provisions in the adhesive manufacturer's approvals/assessments, e.g. with regard to the bonding materials, their pretreatment, the usage temperature, and the documentation requirements must be observed.

In general, all façade cladding materials must be protected from moisture and condensation water, rapid temperature shifts, and direct sunlight during transport and storage.

## 3. Tolerances

### 3.1 General information

For a variety of reasons, minor deviations in the finished work can never be ruled out.

The following tolerances must be taken into account when planning and constructing a rear-ventilated rainscreen façade:

- shell tolerances/tolerances of preliminary works
- manufacturing tolerances in the system components
- production and installation tolerances

Tolerances must be distinguished from dimensional changes or deformations caused by temperature shifts, load changes, or moisture absorption. These factors are determined by the physical and chemical properties of building materials. They cannot be prevented and must therefore be considered in addition to the tolerances.

### 3.2 Shell tolerances/tolerances of preliminary works

According to the relevant regulations, the permissible tolerances for wall materials, e.g. in accordance with DIN 18202, considerably greater than for rear-ventilated rainscreen façades. There may thus be considerable differences between the permissible tolerances for preliminary works and the required precision of the finished façade. The dimensional variation in the anchoring base must be checked and documented prior to installation of the façade. The façade structure must ensure that dimensional variations from the planned clearance between the cladding and the anchoring base of up to 20 mm are typically compensated for. Greater dimensional variations must be considered separately and require the agreement of compensatory measures.

Before the façade cladding is constructed, the preliminary works (typically shell and window construction) must be accepted by the building owner (or his agents, e.g. the architect) and thus released to allow subsequent works to begin. The acceptance report must, in particular, specifically record the basis (e.g. DIN 18202 or individual agreements) for the dimensional tolerances and their compliance or deviation (e.g. using measuring reports, target/actual tables).

The acceptance report must be submitted to the façade contractor in good time prior to the start of construction. He is using the measuring report and checks the deviations with the tolerance compensation options resulting from the execution plan and the works and installation planning.

As not only visual but also functional aspects, e.g. structural safety and fitness for purpose may be negatively influenced due to the permissible tolerances in accordance with DIN 18202, the dimensional tolerances in accordance with DIN 18202 may need to be reduced in the execution planning for the preliminary works. If this is not done, the necessary measures must be commissioned separately.

In order to meet the special, system-specific quality requirements of a rear-ventilated rainscreen façade, placing enhanced requirements on the preliminary works is also recommended.

### 3.3 Manufacturing tolerances in the system components

The manufacturing tolerances for the system components are set out in the relevant standards, approvals/assessments, and works standard specifications. This concerns the permissible length, width, and thickness tolerances and also applies to flatness tolerances, colour and gloss deviations. When planning the rear-ventilated rainscreen façade, these system-specific component tolerances must be observed and, as applicable, agreed by means of limit samples.

Specific agreements must be made separately.

### 3.4 Production and installation tolerances

The façade as a whole is subject to the requirements of DIN 18202 ("Tolerances in building construction") in accordance with ATV DIN 18351 section 3.1.4.

Permissible tolerances for rear-ventilated rainscreen façades are defined in DIN 18202:

- dimensional tolerances in accordance with table 1
- angular deviations in accordance with table 2
- flatness deviations in accordance with table 3 row 6. Increased requirements in accordance with row 7 must be separately agreed and given technical consideration

Increased requirements must always be individually defined, agreed, and planned for the application in due consideration of detailed connections and interfaces to system components. The installation requirements must also be taken into account. Further system and material requirements must be identified and implemented by the planner.

A standardised joint pattern completes the appearance of a rear-ventilated rainscreen façade with cladding that highlights the joints. For the reasons given above, however, deviations in joint widths cannot be fully ruled out.

The significance of a joint's visual appearance for the overall component must be given good consideration.

Section 3.4.1.1 ATV DIN 18351 states that joints must be evenly spread out. No further criteria are specified in the relevant regulations. The criterion of "even" joints, in the sense of this guideline, is met if a viewer cannot ascertain any visible deviations from a typical distance of around 3 metres.

The FVHF further recommends reaching agreement on permissible dimensional variations in the joint widths prior to the start of construction.

### 3.5 Recommendations for agreements of tolerances

Tolerances must be considered and agreed at the planning stage.

At the tolerance agreement the finished surfaces, base, product, cut, and installation tolerances as a whole must be taken into account. The compensation options in the structure must be observed at the same time.

Permissible tolerances and their method of measurement on the finished work should be agreed for the following points:

- lengths and widths of the cladding elements
- deviations from stated alignments and heights
- joint width, joint offset: the tolerance of the finished joint widths results from the temperature and material-related dimensional changes and the permissible production and installation tolerances, and should be agreed at at least +/-20 percent of the joint width. Example: 10 mm joint +/- 20 percent results in a joint width of 8 to 12 mm. Of overriding importance is an even overall impression in the joint pattern
- Façade flatness: the surface of the façade cladding must be flat. Unevenness in the anchoring base must be taken into account at the planning stage and compensated for by the substructure. Individual tolerances must be agreed for different cladding materials. If using thin sheeting, waviness cannot generally be prevented and is not a defect as such (see also the IFBS specialist rules for lightweight metal construction I planning and construction)
- Colour, gloss, surface: samples are suitable here; ideally, limit samples should be agreed. Colour and gloss may vary within the limit samples (see also the IFBS specialist rules for lightweight metal construction I basics).

### 3.6 Acceptance of completed work

In practice, it must be assumed that minor tolerances that do not spoil the overall impression of the façade are acceptable. This, in particular, concerns colour deviations, flatness imperfections, and minor damage. These imperfections must generally be assessed under typical conditions with respect to viewing distance, viewing angle, and lighting situation. Imperfections, e.g. on a wall area on the third storey, are less relevant than those on the surfaces of a prestigious entrance hall.

The assessments must be carried out in diffuse light, never under sidelight or direct sunlight.

Cases in which there is disagreement between the contractor and building owner regarding the permissibility of visual flaws require an expert evaluation using generally accepted evaluation systems for building work (e.g. Oswald evaluation matrix).

When considering façade surfaces, the fact that façades are hand-crafted building products created under site conditions must be taken into consideration.

## 4. Diagrammatic figures

The following figures of rear-ventilated rainscreen façade details are examples for planning and work execution. They are not true-to-scale representations of façade areas and are provided only to illustrate the descriptions given in the text.

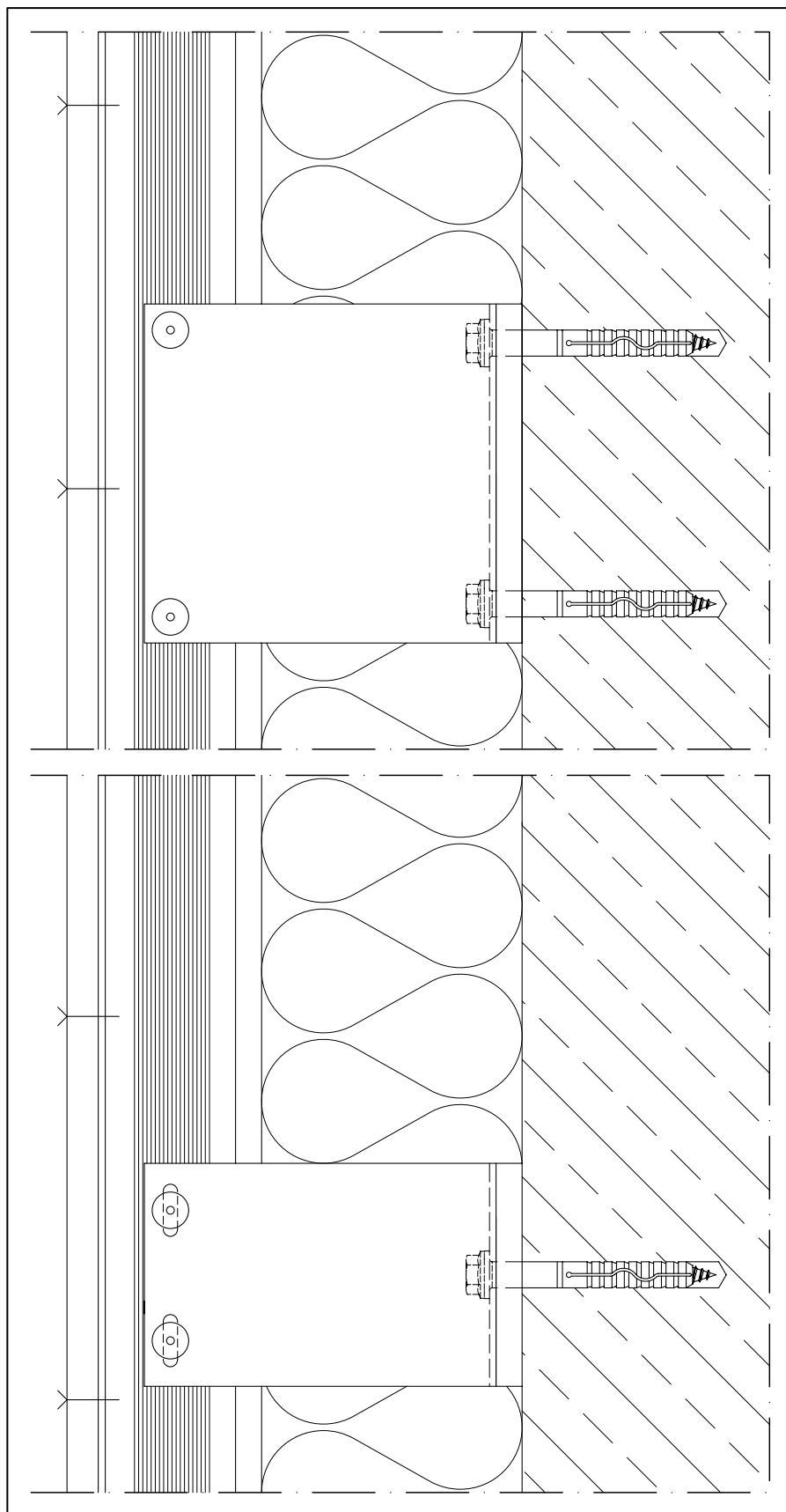

Figure 9: System section, vertical, with fixed and sliding point

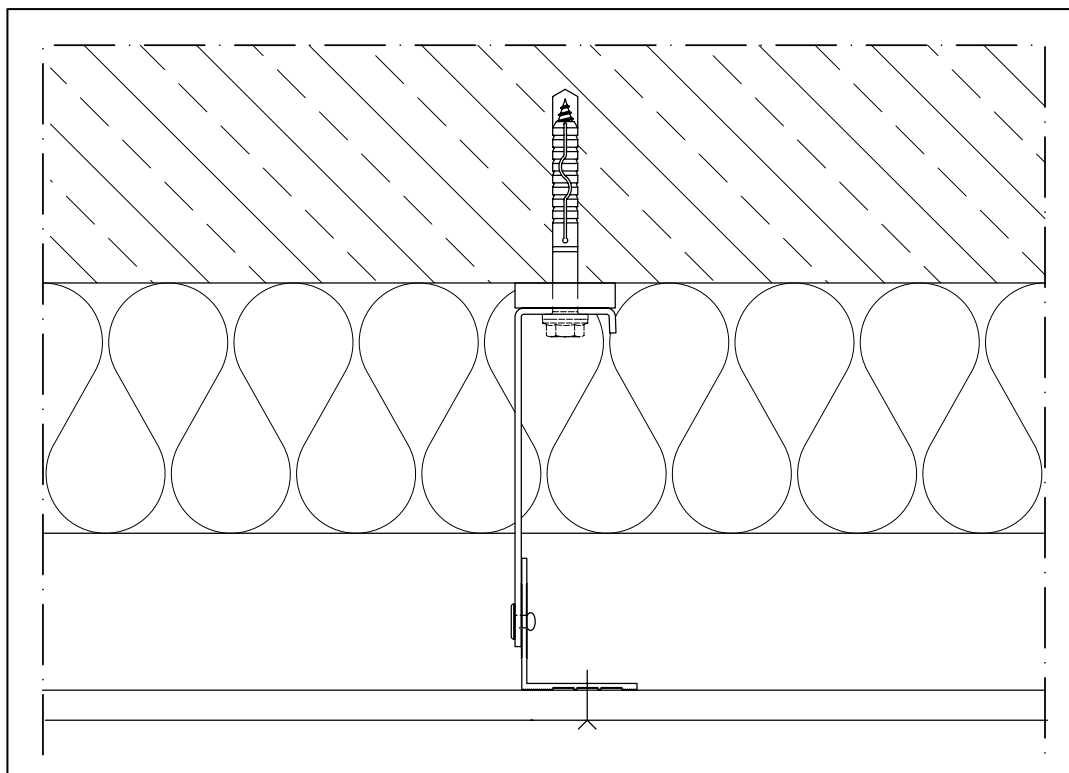

Figure 10: System section, horizontal, fastening "in the field"

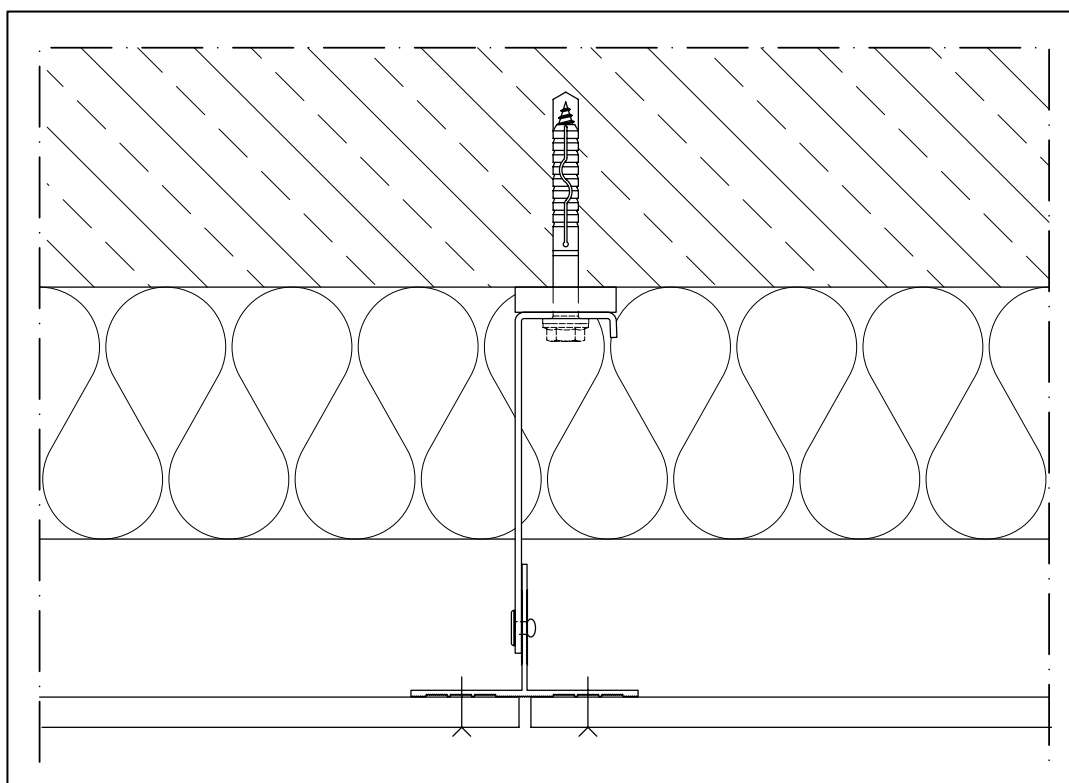

Figure 11: System section, horizontal, fastening with vertical joint

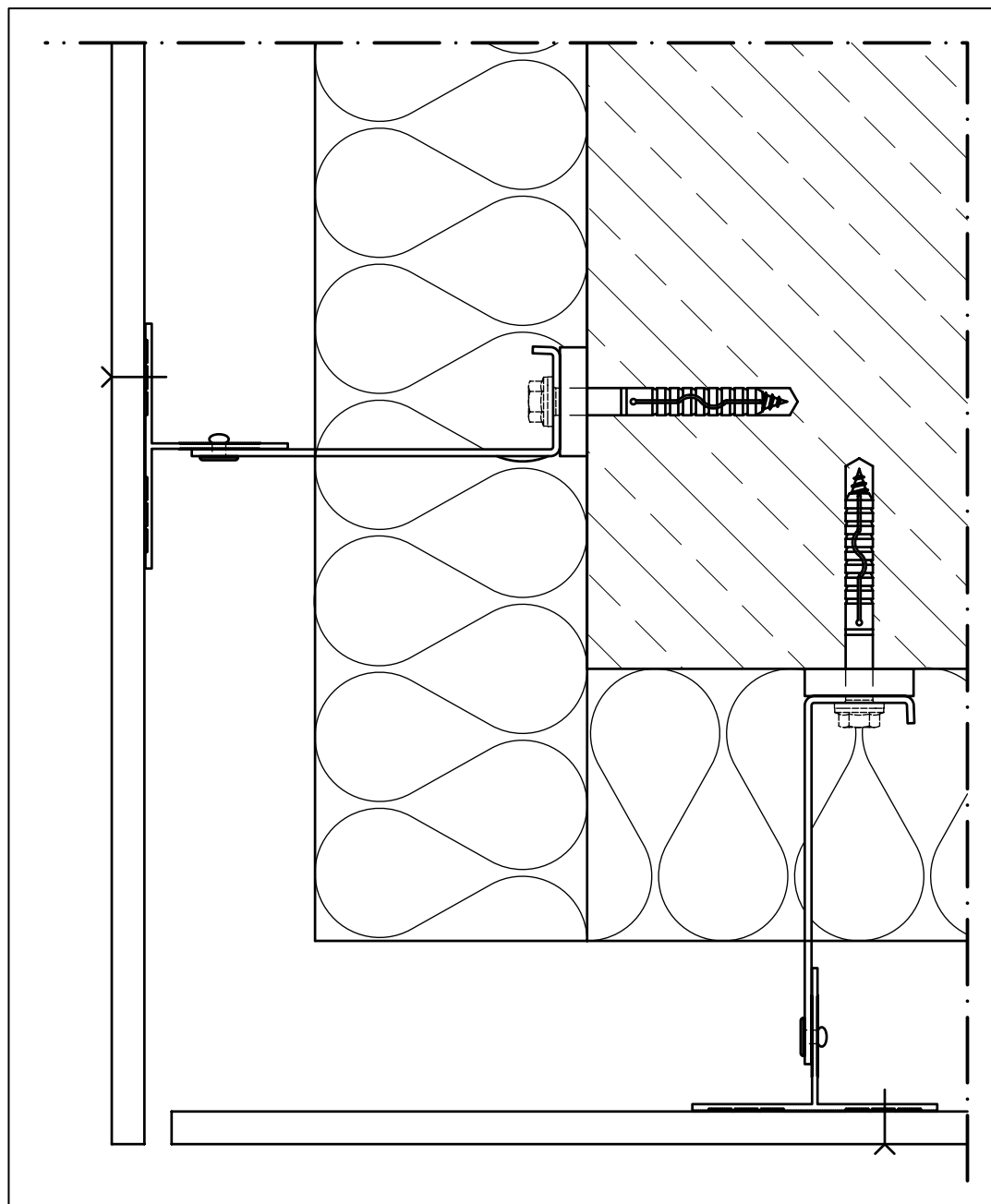

Figure 12: Outer corner with open joint



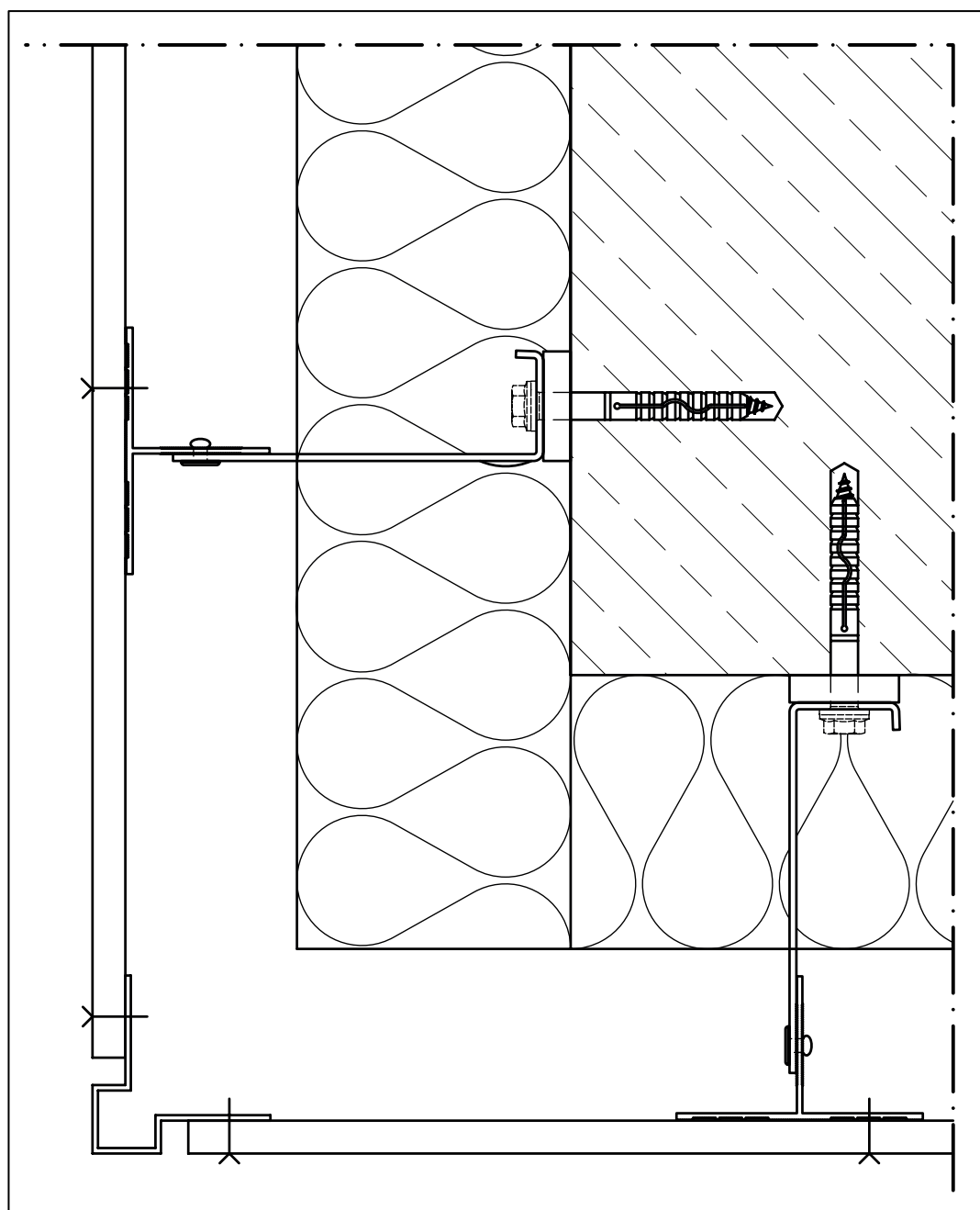

Figure 13: Outer corner with corner profile

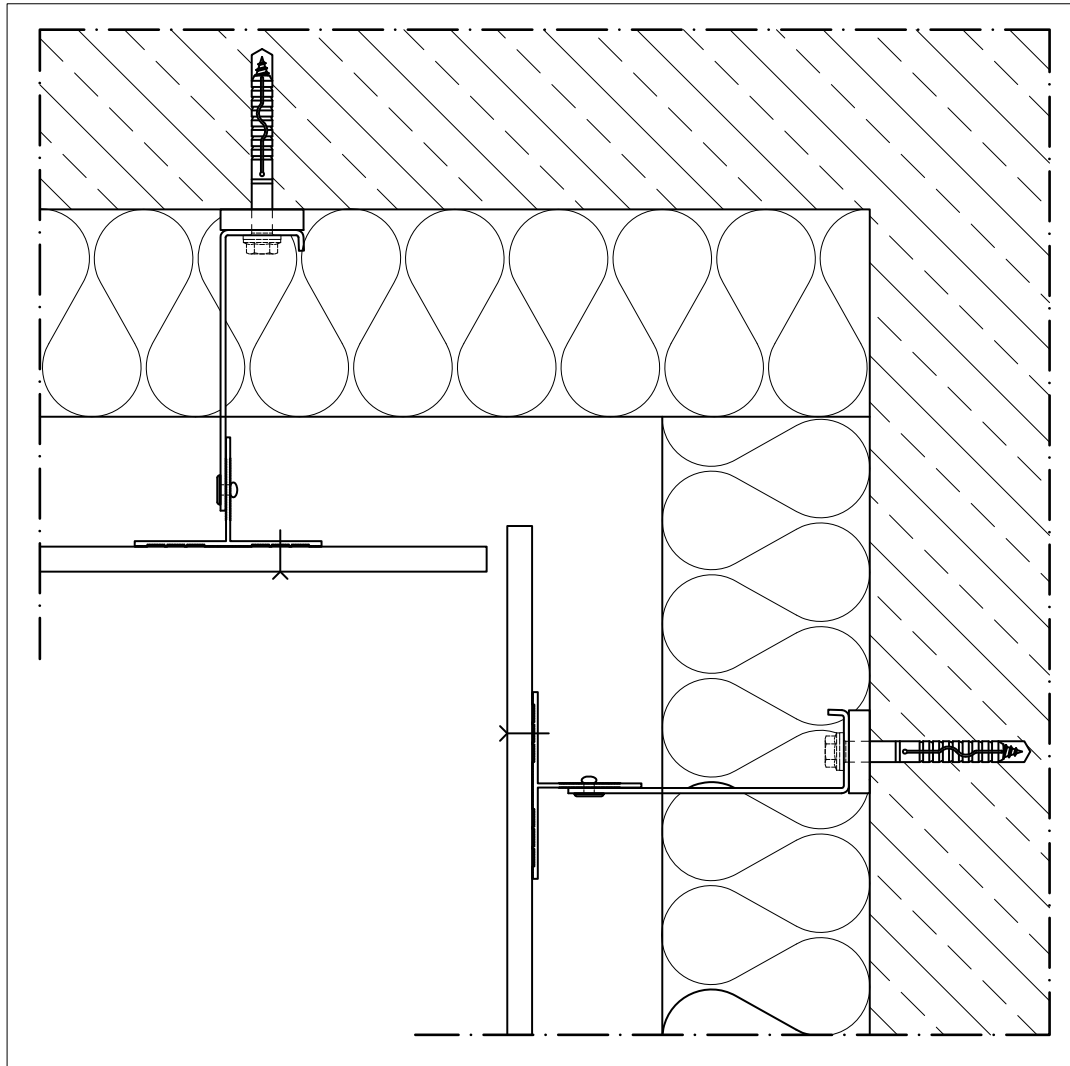

Figure 14: Inner corner with open joint

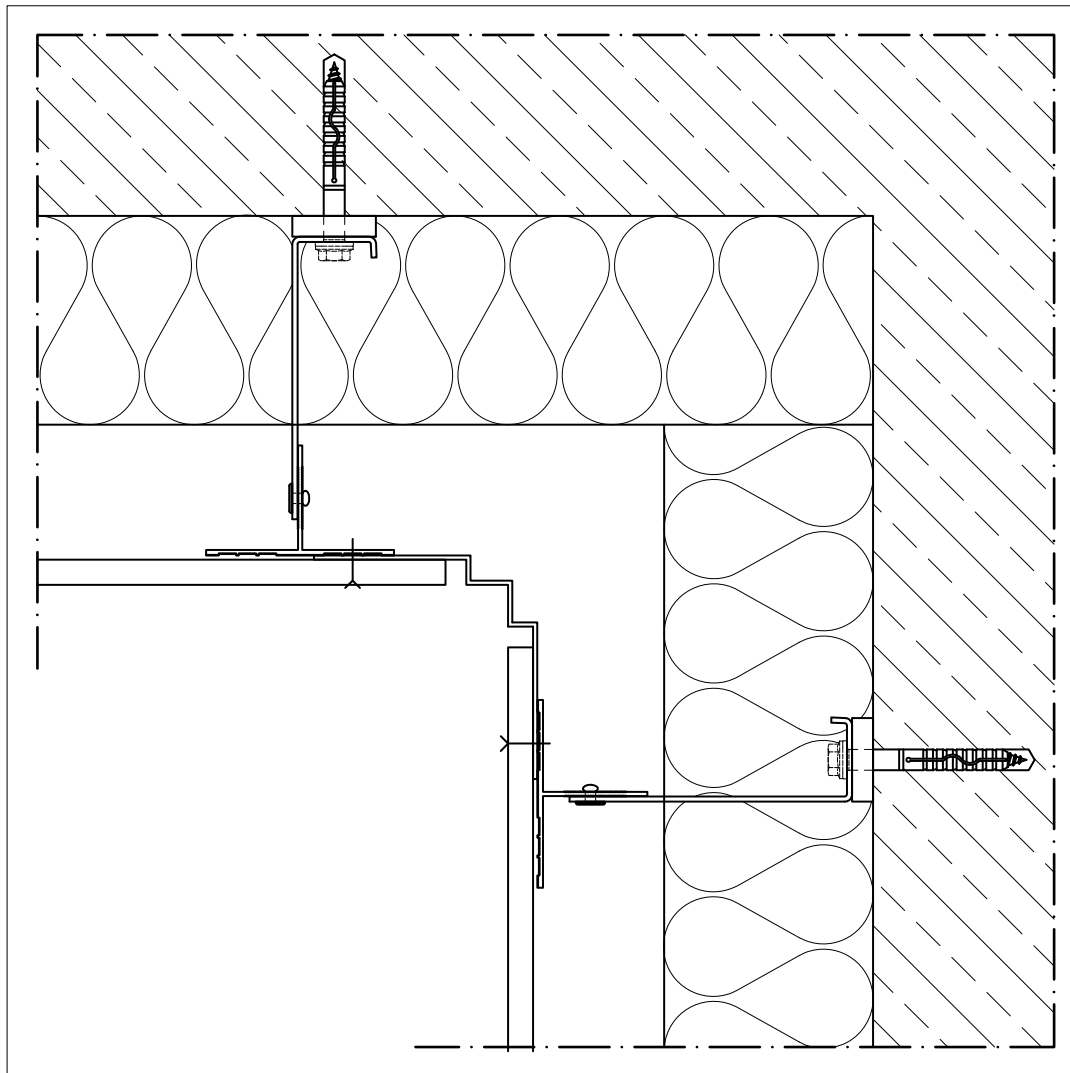

Figure 15: Inner corner with corner profile

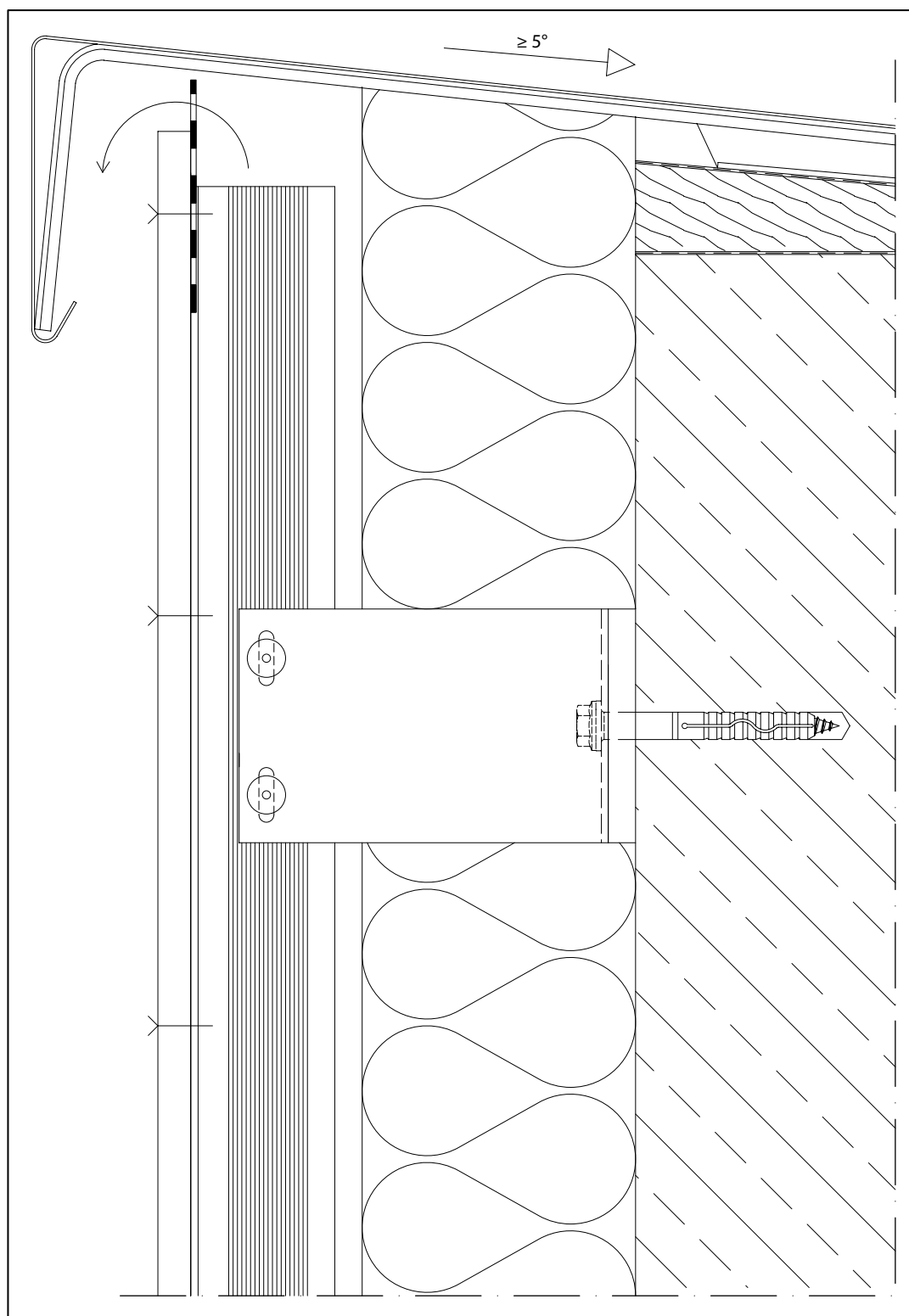

Figure 16: Upper termination/parapet

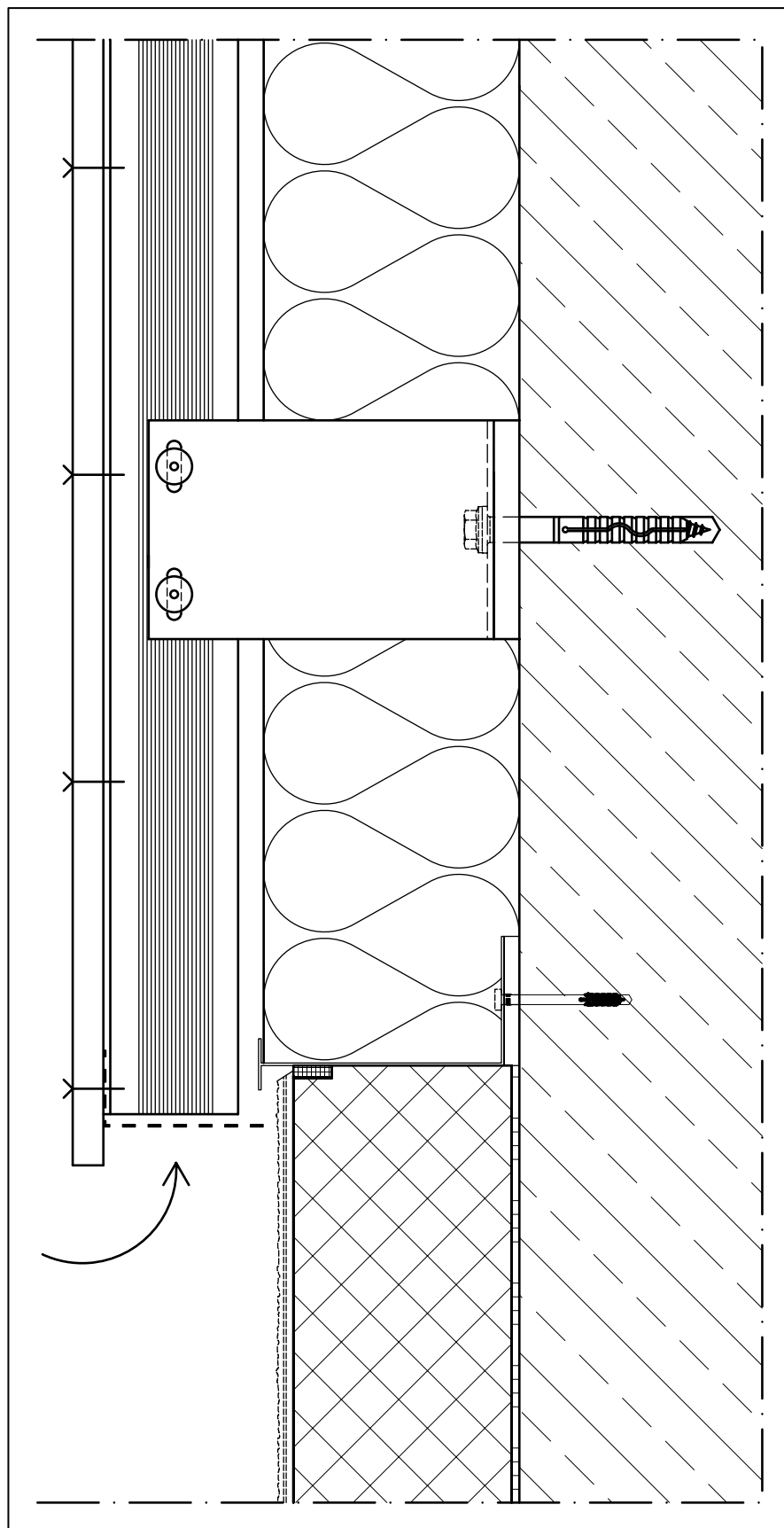

Figure 17: Lower termination/façade base

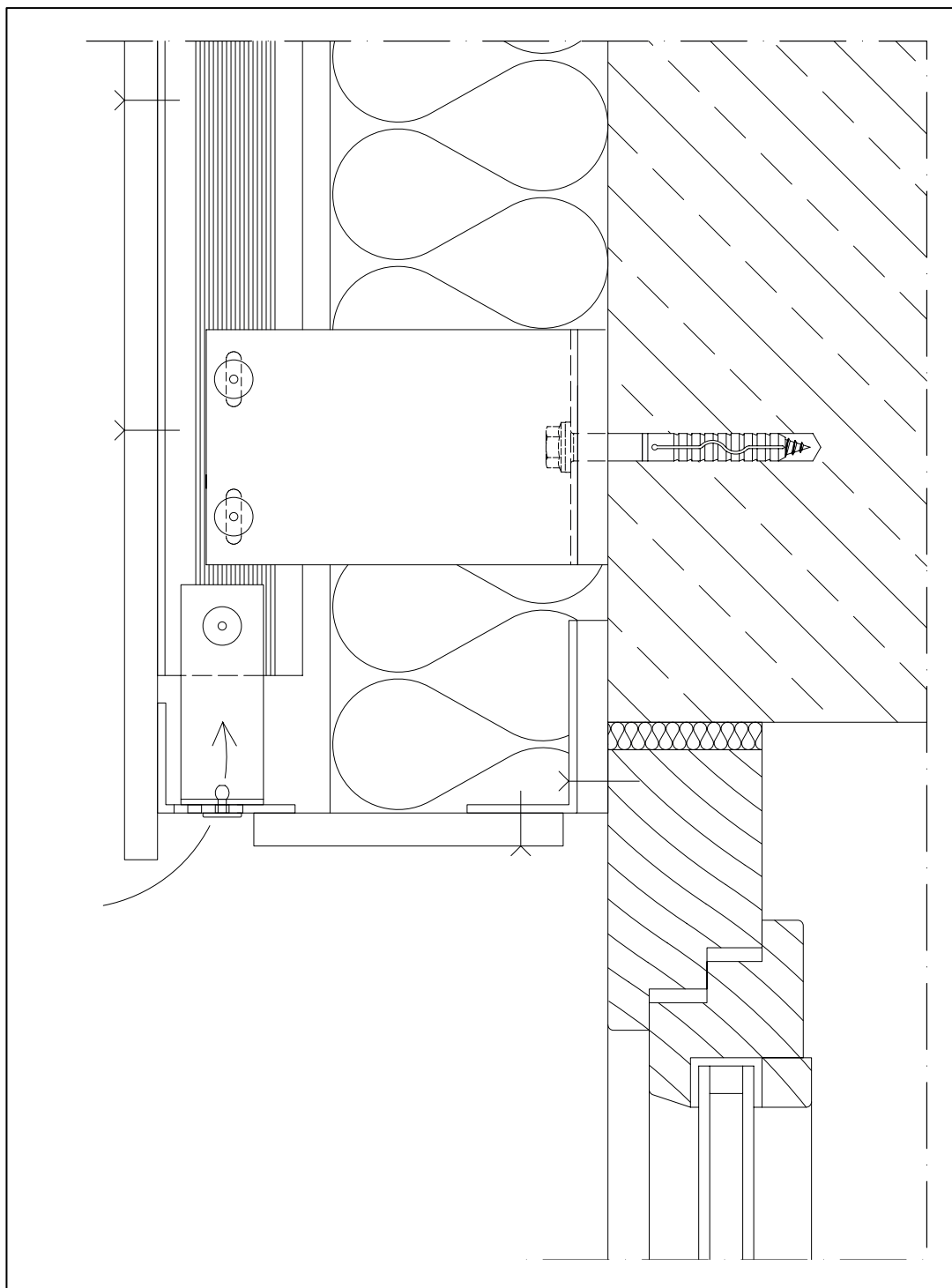

Figure 18: Window lintel

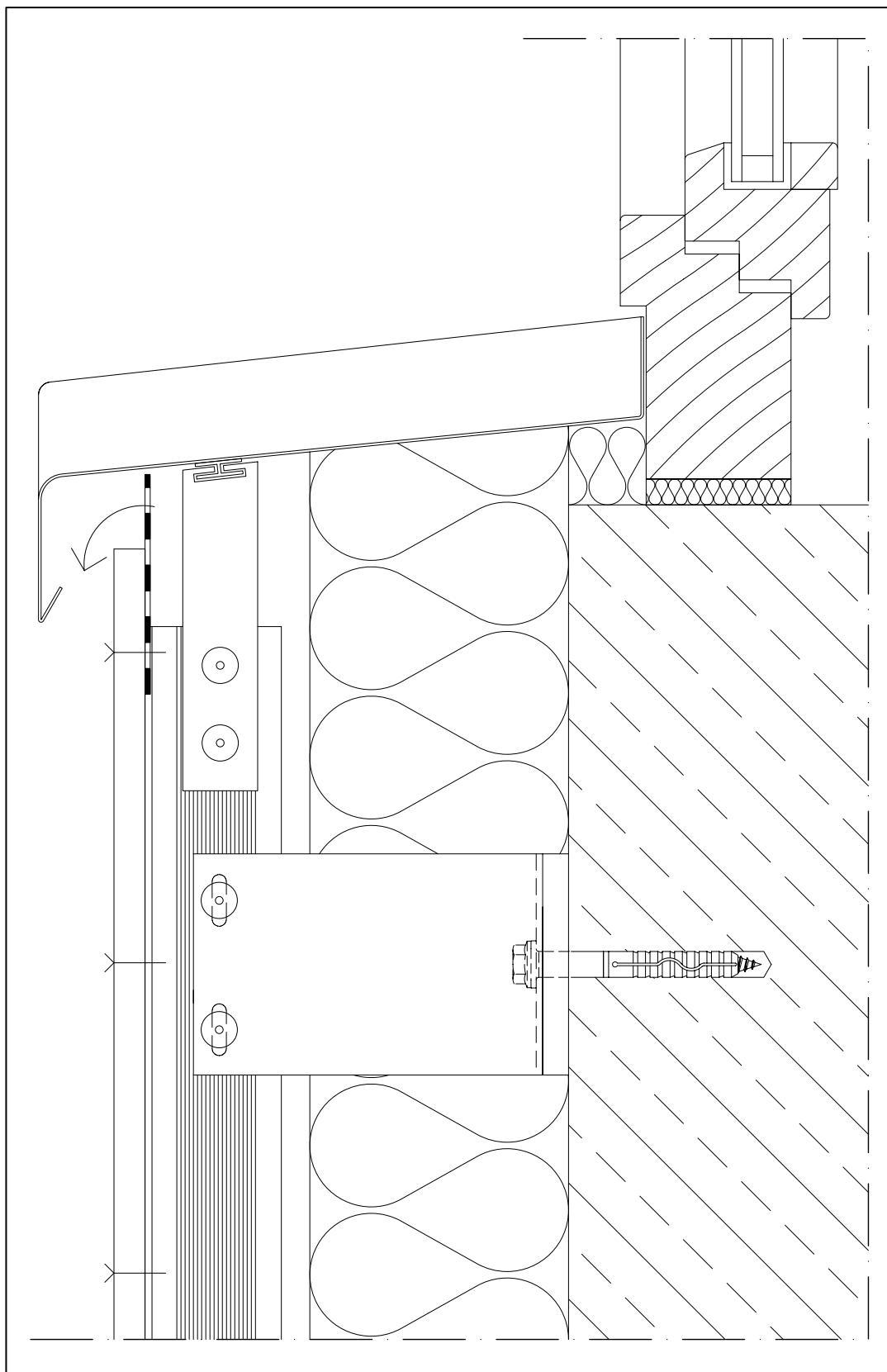

Figure 19: Window sill

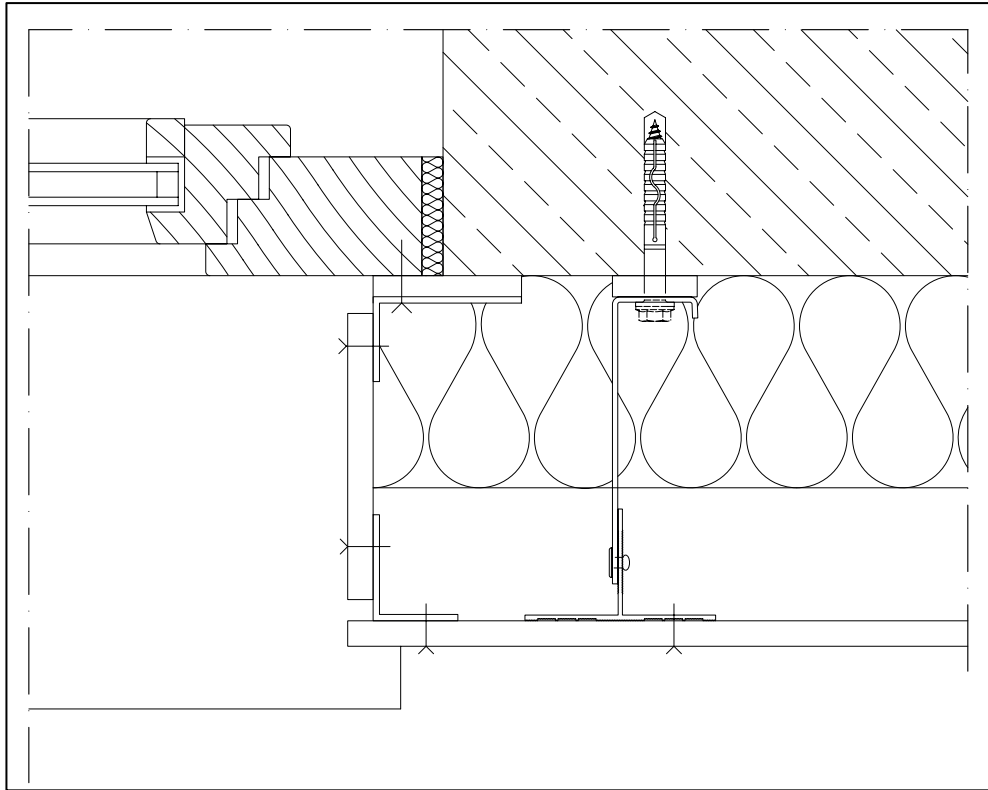

Figure 20: Reveal with cladding material

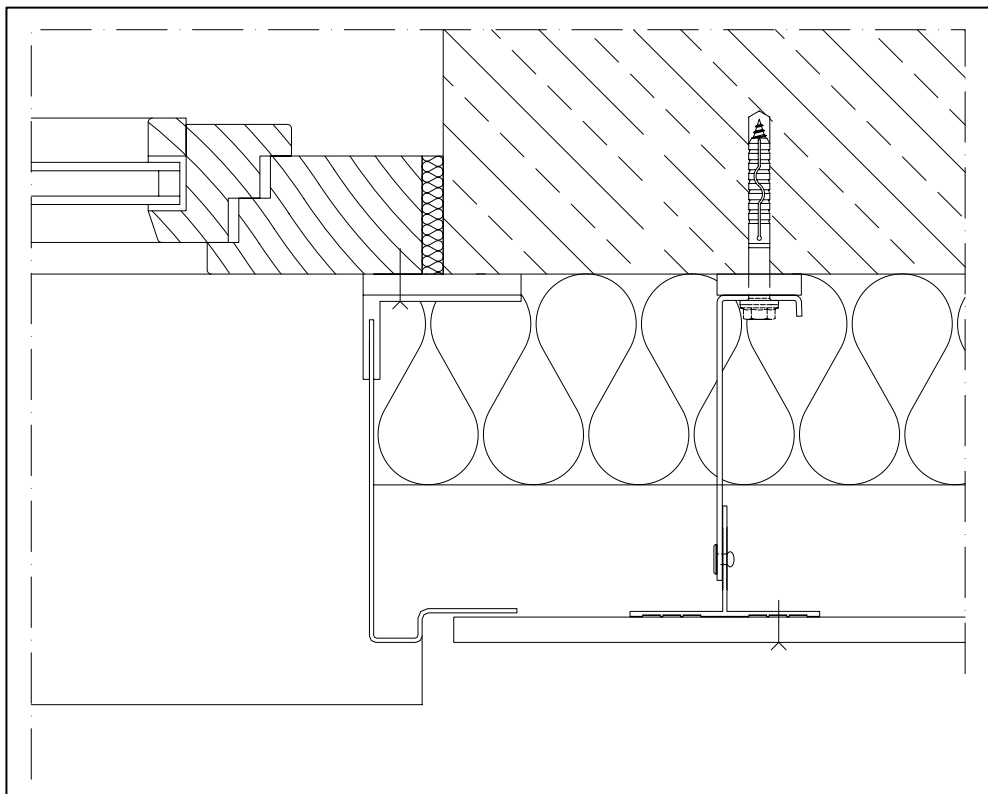

Figure 21: Reveal with profile frame



## 5. References to standards (selection)/bibliography

DIN 18516 – Cladding for external walls, ventilated at rear - Parts 1, 3, and 5

German construction contract procedures (VOB) - Part C: General technical specifications in construction contracts (ATV) - Work on back-ventilated curtain walling

DIN 18008 – Glass in Building - Design and construction rules -

DIN EN ISO 10088 – Stainless steels - Parts 1 to 5

Data base oriented text system for the standardized description of construction work – STLB, number 038, Rear-Ventilated rainscreen Façade

National model building code (MBO)/State Building Code (LBO)

Model List of Technical Building Rules (ML TB)/State List of Technical Building Rules (to be replaced by MVV TB in future)

Administrative Rule on Technical Building Rules (MVV TB) (will replace ML TB on launch)

FVHF guideline on fire protection precautions for rear-ventilated rainscreen façades in accordance with DIN 18516-1, see [www.FVHF.de](http://www.FVHF.de)

Energy Saving Ordinance (EnEV)

Guideline on determining the thermal influences of thermal bridges with rear-ventilated rainscreen façades, edition 1998; publisher: Fachverband Baustoffe und Bauteile für vorgehängte hinterlüftete Fassaden e.V. FVHF

Guideline on planning, executing, and maintaining façade greening and climbing plants; publisher: Forschungsgesellschaft Landschaftsentwicklung Landschaftsbau e.V. (FLL)

Recommendations for planning, building, and maintaining transition areas between open spaces and buildings; publisher: Forschungsgesellschaft Landschaftsentwicklung Landschaftsbau e.V. (FLL)

DAST Guideline 022 - hot-dip galvanising of steel components; publisher: Industrieverband Feuerverzinken

ETAG 001 Guideline for European technical approval of metal anchors for use in concrete

ETAG 020 Guideline for European technical approval of plastic anchors for multiple use in concrete and masonry for non-structural applications

ETAG 029 Guideline for European technical approval of metal injection anchors for use in masonry

ETAG 034 Guideline for European technical approval of kits for external wall claddings, parts 1 and 2

National Technical Approval 30.3-6. “Products, connecting devices, and structural components made from stainless steel”

DIN EN 1993-1-4/NA: 2017-01 National Annex - Nationally determined parameters - Eurocode 3: Design of steel structures - Part 1-4: General rules - Supplementary rules for stainless steels

FVHF series “In Focus”, see [www.FVHF.de](http://www.FVHF.de)

IFBS specialist rule for lightweight metal construction – planning and construction

## FVHF

Fachverband Baustoffe und Bauteile  
für vorgehängte hinterlüftete Fassaden e.V.

Kurfürstenstraße 129

D - 10785 Berlin

Tel. +49 (0)30 212862-81

Email: [info@FVHF.de](mailto:info@FVHF.de)

[www.FVHF.de](http://www.FVHF.de)